

**Massachusetts  
Tests for Educator Licensure<sup>®</sup> (MTEL<sup>®</sup>)**



**Physics (11)**

**PRACTICE TEST**



All examinees taking the Physics (11) test will be provided with a scientific calculator with functions that include the following: addition, subtraction, multiplication, division, square root, percent, sine, cosine, tangent, exponents, and logarithms. Refer to "Test Selection" in the current MTEL registration bulletin for more information.



**[www.mtel.nesinc.com](http://www.mtel.nesinc.com)**

Copyright © 2010 Pearson Education, Inc. or its affiliate(s). All rights reserved.  
Evaluation Systems, Pearson, P.O. Box 226, Amherst, MA 01004

Massachusetts Tests for Educator Licensure and MTEL are trademarks, in the U.S. and/or other countries, of the Massachusetts Department of Elementary and Secondary Education and Pearson Education, Inc. or its affiliate(s).  
Pearson and its logo are trademarks in the U.S. and/or other countries of Pearson Education, Inc. or its affiliate(s).

## TABLE OF CONTENTS

Introduction .....	1
Purpose of the Practice Test .....	1
Taking the Practice Test .....	1
Incorporating the Practice Test in Your Study Plan .....	1
Physics Practice Test .....	2
Constants/Formulas .....	3
General Test Directions .....	7
Multiple-Choice Answer Sheet .....	8
Multiple-Choice Questions .....	9
Directions for the Open-Response Item Assignments .....	42
Open-Response Item Assignments and Response Sheets .....	43
Practice Test Results .....	49
Practice Test Results Overview .....	50
Multiple-Choice Question Answer Key Worksheet .....	51
Multiple-Choice Question Practice Test Evaluation Chart .....	54
Open-Response Item Evaluation Information .....	58
Open-Response Item Scoring Rubric, Sample Responses, and Analyses .....	59
Practice Test Score Calculation .....	75

*Readers should be advised that this practice test, including many of the excerpts used herein, is protected by federal copyright law.*

*Test policies and materials, including but not limited to tests, item types, and item formats, are subject to change at the discretion of the Massachusetts Department of Elementary and Secondary Education.*

## INTRODUCTION

This document is a printable version of the Massachusetts Tests for Educator Licensure® (MTEL®) Physics (11) Online Practice Test. This practice test is a sample test consisting of 100 multiple-choice questions and 2 open-response item assignments.

To assist you in recording and evaluating your responses on the practice test, a [Multiple-Choice Answer Sheet](#), an [Answer Key Worksheet](#), and an [Evaluation Chart](#) by test objective are included for the multiple-choice questions. A blank [Response Sheet](#), [Evaluation Information](#), and [Sample Responses and Analyses](#), as well as a [Scoring Rubric](#), are included for the open-response items. Lastly, there is a [Practice Test Score Calculation](#) worksheet.

## PURPOSE OF THE PRACTICE TEST

The practice test is designed to provide an additional resource to help you effectively prepare for the MTEL Physics (11) test. The primary purpose of the practice test is to help you become familiar with the structure and content of the test. It is also intended to help you identify areas in which to focus your studies. Education faculty and administrators of teacher preparation programs may also find this practice test useful as they help students prepare for the official test.

## TAKING THE PRACTICE TEST

In order to maximize the benefits of the practice test, it is recommended that you take this test under conditions similar to the conditions under which the official MTEL tests are administered. Try to take the practice test in a quiet atmosphere with few interruptions and limit yourself to the four-hour time period allotted for the official test administration. You will find your results to be more useful if you refer to the answer key only after you have completed the practice test.

## INCORPORATING THE PRACTICE TEST IN YOUR STUDY PLAN

Although the primary means of preparing for the MTEL is your college education, adequate preparation prior to taking or retaking the MTEL test is strongly recommended. How much preparation and study you need depends on how comfortable and knowledgeable you are with the content of the test.

The first step in preparing to take the MTEL is to identify what information the test will address by reviewing the objectives for your field. A complete, up-to-date list of the [Test Objectives](#) is included in the [Test Information Booklet](#) for each test field. The test objectives are the core of the testing program and a helpful study tool. Before taking or retaking the official test, focus your study time on those objectives for which you wish to strengthen your knowledge.

This practice test may be used as one indicator of potential strengths and weaknesses in your knowledge of the content on the official test. However, because of potential differences in format and difficulty between the practice test and an official MTEL Physics (11) test, it is not possible to predict precisely how you might score on an official MTEL Physics (11) test. Keep in mind that the subareas for which the test weighting is greatest will receive emphasis on this test. Refer to the [Test Information Booklet](#) for additional information about how to prepare for the test.

**PHYSICS  
PRACTICE TEST**

Candidates taking the Physics test (field 11) will be provided with the constants and formulas shown below at the test administration.

### CONSTANTS

Description	Value
Acceleration of gravity on Earth ( $g$ )	$9.80 \text{ m/s}^2$
Speed of light in a vacuum ( $c$ )	$3.00 \times 10^8 \text{ m/s}$
Planck's constant ( $h$ )	$6.63 \times 10^{-34} \text{ J}\cdot\text{s} = 4.14 \times 10^{-15} \text{ eV}\cdot\text{s}$
Electron rest mass	$9.11 \times 10^{-31} \text{ kg}$
Proton rest mass	$1.67 \times 10^{-27} \text{ kg}$
Charge of electron	$-1.60 \times 10^{-19} \text{ C}$
Coulomb's constant ( $k_e$ )	$9.0 \times 10^9 \text{ N}\cdot\text{m}^2/\text{C}^2$
Boltzmann constant ( $k_b$ )	$1.38 \times 10^{-23} \text{ J/K}$
Gas constant ( $R$ )	$8.31 \text{ J}/(\text{mol}\cdot\text{K})$
Gravitational constant ( $G$ )	$6.67 \times 10^{-11} \text{ N}\cdot\text{m}^2/\text{kg}^2$
Permeability of free space ( $\mu_0$ )	$4\pi \times 10^{-7} \text{ T}\cdot\text{m/A}$
Avogadro's number	$6.02 \times 10^{23}$

## FORMULAS

Nature of Science	Force and Motion
$C = 2\pi r$	$v_f = v_i + at$
$A = \pi r^2$	$x_f = x_i + v_i t + \frac{1}{2}at^2$
$SA = 4\pi r^2$	$v_f^2 - v_i^2 = 2a(x_f - x_i)$
$V = \frac{4}{3}\pi r^3$	$a_c = \frac{v^2}{r}$
$\frac{d}{dx} x^n = nx^{n-1}$	$F = -kx$
$\frac{d}{dx} Ce^{ax} = aCe^{ax}$	$F \leq \mu N$
$\frac{d}{dx} A \sin bx = Ab \cos bx$	$F = \frac{Gm_1 m_2}{r^2}$
$\frac{d}{dx} A \cos bx = -Ab \sin bx$	$\theta_f = \theta_i + \omega_i t + \frac{1}{2}\alpha t^2$
$\int x^n dx = \frac{1}{n+1} x^{n+1} + C, n \neq -1$	$\omega_f = \omega_i + \alpha t$
$\int \frac{dx}{x} = \ln x + C$	$v = r\omega$
	$a = r\alpha$
	$r = \frac{\sum mr}{\sum m}$
	$I = \int r^2 dm$
	$I = \sum mr^2$
	$\boldsymbol{\tau} = \mathbf{r} \times \mathbf{F}$
	$\sum \boldsymbol{\tau} = I\boldsymbol{\alpha}$
	$KE = \frac{1}{2}I\omega^2$
	$\mathbf{L} = \mathbf{r} \times \mathbf{p}$
	$L = I\omega$
	$P = \rho gh$
	$F = \rho Vg$
	$A_1 v_1 = A_2 v_2$
	$P + \frac{1}{2}\rho v^2 + \rho gy = \text{constant}$

## FORMULAS (continued)

Energy, Momentum, and Heat Transfer	Electricity and Magnetism
$W = \int F dx$	$F = \frac{k_e q_1 q_2}{r^2}$
$KE = \frac{1}{2}mv^2$	$\mathbf{E} = \frac{\mathbf{F}}{q_0}$
$PE = mgh$	$\oint \mathbf{E} \cdot d\mathbf{A} = 4\pi k_e q$
$PE = \frac{1}{2}kx^2$	$V = -\int \mathbf{E} \cdot d\mathbf{r}$
$\int F dt = \Delta p$	$V = \frac{k_e q}{r}$
$\Delta l = \alpha l_0 \Delta T$	$R = \frac{\rho l}{A}$
$\Delta Q = mc\Delta T$	$V = IR$
$\Delta Q = mL$	$R_s = \sum R_i$
$\frac{\Delta Q}{\Delta t} = \frac{kA\Delta T}{d}$	$\frac{1}{R_p} = \sum \frac{1}{R_i}$
$PV = nRT$	$P = IV$
$\frac{1}{2}m\overline{v^2} = \frac{3}{2}k_b T$	$C = \frac{Q}{V}$
$\Delta E = Q - P\Delta V$	$C_p = \sum C_i$
$e = \frac{T_h - T_c}{T_h}$	$\frac{1}{C_s} = \sum \frac{1}{C_i}$
	$\mathbf{F} = q\mathbf{v} \times \mathbf{B}$
	$\mathbf{F} = I\mathbf{l} \times \mathbf{B}$
	$\oint \mathbf{B} \cdot d\mathbf{l} = \mu_0 I$
	$\mathcal{E}_{\text{avg}} = -\frac{\Delta\Phi}{\Delta t}$
	$\Phi = B_{\perp}A$

FORMULAS (continued)

Waves, Sound, and Light	Modern Physics
$a = -\omega^2 x$	$E = hf$
$x = A \sin \omega t$	$E = mc^2$
$T = 2\pi\sqrt{\frac{m}{k}}$	$\gamma = \frac{1}{\sqrt{1 - \frac{v^2}{c^2}}}$
$T = 2\pi\sqrt{\frac{L}{g}}$	$hf = \phi + eV$
$v = f\lambda$	$\Delta x \Delta p \geq h$
$v = \sqrt{\frac{T}{\mu}}$	$\Delta E \Delta t \geq h$
$v = \sqrt{\frac{\gamma RT}{M}}$	$p = \frac{h}{\lambda}$
$2L = n\lambda, n$ is an integer	
$4L = n\lambda, n$ is odd	
$n_1 \sin \theta_1 = n_2 \sin \theta_2$	
$n = \frac{c}{v}$	
$\frac{1}{f} = \frac{1}{s_i} + \frac{1}{s_o}$	
$M = \frac{h_i}{h_o} = -\frac{s_i}{s_o}$	
$d \sin \theta = m\lambda$	
$I = I_0 \cos^2 \theta$	

NOTES FOR PHYSICS TEST

Not all formulas necessary are listed, nor are all formulas listed used on this test.

In questions on electricity and magnetism, the term *current* refers to "conventional current" and the use of the right-hand rule is assumed.

## GENERAL TEST DIRECTIONS

This practice test consists of two sections: (1) a multiple-choice question section and (2) an open-response item assignment section. Each multiple-choice question on the practice test has four answer choices. Read each question carefully and choose the ONE best answer. Record each answer on the answer sheet provided.

- Sample Question:
1. What is the capital of Massachusetts?
    - A. Worcester
    - B. New Bedford
    - C. Boston
    - D. Springfield

The correct answer to this question is C. You would indicate that on the answer sheet.

The open-response section of this practice test requires written responses. Directions for the open-response item assignments appear immediately before those assignments.

You may work on the multiple-choice questions and open-response item assignments in any order that you choose. You may wish to monitor how long it takes you to complete the practice test. When taking the actual MTEL Physics (11) test, you will have one four-hour test session in which to complete the test.

**MULTIPLE-CHOICE ANSWER SHEET**

<b>Question Number</b>	<b>Your Response</b>
1	
2	
3	
4	
5	
6	
7	
8	
9	
10	
11	
12	
13	
14	
15	
16	
17	
18	
19	
20	
21	
22	
23	
24	
25	
26	
27	
28	
29	
30	
31	
32	
33	
34	

<b>Question Number</b>	<b>Your Response</b>
35	
36	
37	
38	
39	
40	
41	
42	
43	
44	
45	
46	
47	
48	
49	
50	
51	
52	
53	
54	
55	
56	
57	
58	
59	
60	
61	
62	
63	
64	
65	
66	
67	
68	

<b>Question Number</b>	<b>Your Response</b>
69	
70	
71	
72	
73	
74	
75	
76	
77	
78	
79	
80	
81	
82	
83	
84	
85	
86	
87	
88	
89	
90	
91	
92	
93	
94	
95	
96	
97	
98	
99	
100	

## MULTIPLE-CHOICE QUESTIONS

1. Which of the following is the primary goal of scientific inquiry?

- A. finding technological solutions to human problems
- B. discovering the fundamental principles that govern nature
- C. developing mathematical techniques for solving problems
- D. investigating fundamental principles that transcend the material world

2. Which of the following is the best example of a testable hypothesis?

- A. Why do both Coulomb's law and Newton's law of gravitation obey an inverse square relationship?
- B. Will an incandescent lamp last longer if it is left on continuously or rapidly turned on and off?
- C. When is it most important to apply the laws of quantum physics in place of those of classical physics?
- D. Why does light refract as it moves from one optical medium to another?

3. A student is investigating factors that affect the strength of an electromagnet. The student proposes the following design.

**Factors:** Voltage, number of turns of wire.

**Process:** Set voltage to 2.0 V, wrap 50 turns of wire around an iron coil. Measure how many paper clips the magnet can pick up. Set voltage to 4.0 V and wrap 30 more turns of wire. Again measure the number of paper clips. Repeat several times.

Which of the following is the most significant problem with this experimental design?

- A. not accounting for the resistance of the additional length of wire
- B. using paper clips to measure the strength of the electromagnet
- C. using increments of 2.0 V instead of 1.0 V
- D. changing the values of two factors at the same time

4. Which of the following guidelines should be followed when keeping a laboratory notebook?
- A. Reorganize the notebook by cleaning up data, notes, and records before each new lab.
  - B. Round all data values to two significant figures before recording.
  - C. Date and record all procedures, events, and original data in ink to prevent erasures.
  - D. Keep a separate notebook to record calculations and sketches.
5. Which of the following calculations can be used for curve fitting?
- A. the chi-square distribution
  - B. least-squares regression
  - C. the correlation coefficient
  - D. the standard deviation of a sample
6. The dimensions of a rectangular solid block are given below.
- length = 1.55 cm  
width = 4.2 cm  
height = 0.87 cm
- Which of the following values expresses the volume of the block using the correct number of significant figures?
- A. 5.7 cm<sup>3</sup>
  - B. 5.66 cm<sup>3</sup>
  - C. 5.67 cm<sup>3</sup>
  - D. 5.664 cm<sup>3</sup>
7. Students in a physics class are learning how to solder electronic components onto a printed circuit board. In addition to working in a well-ventilated area, the students should also wear:
- A. leather gloves.
  - B. safety glasses.
  - C. rubber shoes.
  - D. an antistatic wrist strap.

8. A student would like to measure the electric power used by a laptop computer when placed in the low-power mode. Which of the following pairs of meters should be selected for this measurement?
- A. galvanometer and ammeter
  - B. galvanometer and ohmmeter
  - C. voltmeter and ammeter
  - D. ohmmeter and voltmeter
9. Students in a physics class have been creating electrochemical cells using various chemical solutions. Which of the following would be the best source of information for properly storing and disposing of the chemicals?
- A. reference guide of physics and chemistry data and formulas
  - B. laboratory manual for introductory physics
  - C. National Science Teachers Association (NSTA)
  - D. Material Safety Data Sheets (MSDS)
10. Which of the following experiments led most directly to the quantum theory of light?
- A. Michelson's and Morley's effort to detect the luminiferous ether
  - B. Röntgen's discovery of the emission of X-rays from a vacuum tube
  - C. Planck's analysis of the spectrum emitted by a blackbody
  - D. Hertz's detection of electromagnetic radiation
11. In chemistry, the enthalpy is defined as the heat energy change of a reaction. It is most closely related to which of the following concepts in physics?
- A. the area under a force versus displacement graph
  - B. the slope of the line tangent to a velocity versus time graph
  - C. the area under a force versus time graph
  - D. the slope of the line tangent to a momentum versus time graph

12. Several students in a physics class are planning to design a wind power system that can generate enough electricity to perform hydrolysis of water in a 500 mL beaker. According to the engineering design process, which of the following should the students do first?
- make an expanded sketch of the major parts of the system
  - build a small, working prototype of the system
  - define the problem that needs to be solved
  - brainstorm several alternative designs for the system

13. Newton's laws, when applied in a particular situation, give the following equations.

$$F_n + F \sin \theta - mg = 0$$

$$F \cos \theta - \mu F_n = ma$$

Which of the following equations correctly expresses  $\mu$ ?

- $\mu = \frac{ma - F \cos \theta}{-F \sin \theta - mg}$
- $\mu = \frac{ma + F \cos \theta}{F \sin \theta - mg}$
- $\mu = \frac{-ma + F \cos \theta}{-F \sin \theta + mg}$
- $\mu = \frac{-ma + F \cos \theta}{F \sin \theta - mg}$

14. Use the diagram below to answer the question that follows.

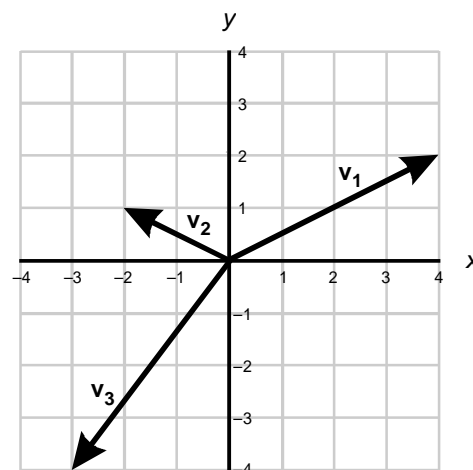

What is the sum of the three vectors shown above, expressed using the unit vectors  $\mathbf{i}$  and  $\mathbf{j}$ ?

- $-1\mathbf{i} + -1\mathbf{j}$
  - $1\mathbf{i} + -1\mathbf{j}$
  - $-1\mathbf{i} + 1\mathbf{j}$
  - $1\mathbf{i} + 1\mathbf{j}$
15. The acceleration of a particle is given by the following equation.
- $$a(t) = 6t^2$$
- Given that  $v(0) = 4$  m/s, what is the velocity of the particle at  $t = 3$  s?
- 36 m/s
  - 50 m/s
  - 54 m/s
  - 58 m/s

16. Use the graph below to answer the question that follows.

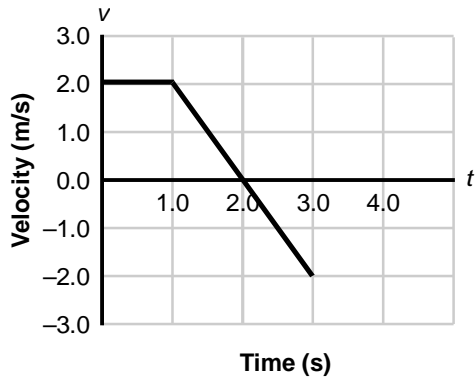

The graph above shows the velocity of a particle moving in a straight line. At  $t = 0$ , the particle is located at  $x = 0$ . Which of the following graphs shows the position of the particle with respect to time,  $x(t)$ ?

A.

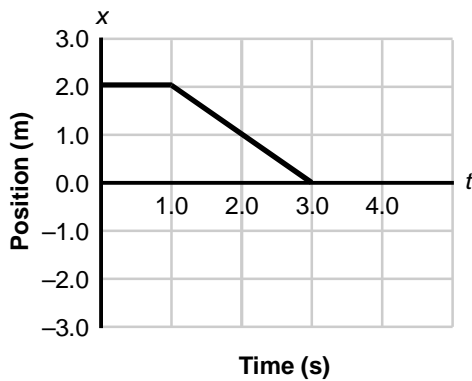

B.

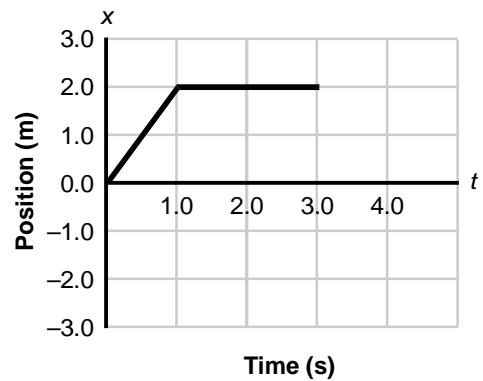

C.

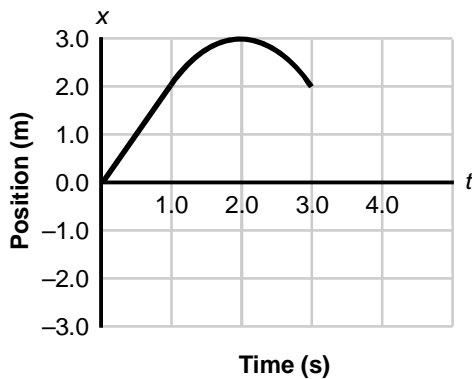

D.

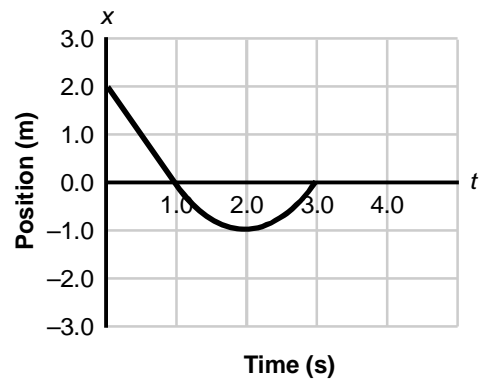

17. Use the diagram below to answer the question that follows.

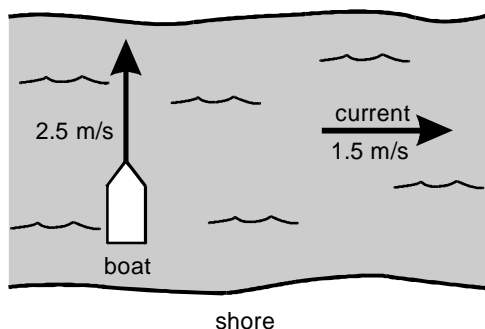

A boat that moves in still water with a speed of 2.5 m/s now heads north across a river that has a current of 1.5 m/s east, as shown in the diagram above. What is the boat's velocity relative to an observer on the shore?

- A. 2.9 m/s at  $31^\circ$  north of east
- B. 2.9 m/s at  $59^\circ$  north of east
- C. 4.0 m/s at  $31^\circ$  north of east
- D. 4.0 m/s at  $59^\circ$  north of east

18. Use the graph below to answer the question that follows.

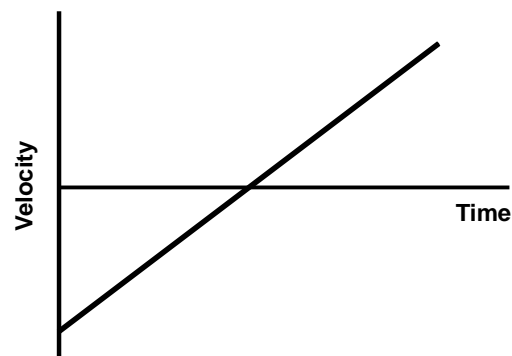

The graph above shows the velocity with respect to time of an object moving in a straight line. The positive direction is to the right and the negative direction is to the left. Which of the following statements best describes the motion of this object?

- A. The object starts at a location to the left of the origin and travels at a constant speed toward the right.
- B. The object starts at a location to the left of the origin at a slow speed and speeds up as it moves to the right.
- C. The object slows down as it moves to the left, stops, and starts moving to the right.
- D. The object slows down as it moves to the right, stops, and continues moving to the right.

19. A car on a highway has an initial speed of 23 m/s. The car accelerates at a constant rate for 10 s to a final speed of 29 m/s. How far does the car travel during this time interval?
- A. 230 m
  - B. 260 m
  - C. 275 m
  - D. 290 m
20. A car traveling at 12 m/s slows down and comes to a stop in 20 m. What is the acceleration of the car, assuming it is constant?
- A.  $-7.2 \text{ m/s}^2$
  - B.  $-3.6 \text{ m/s}^2$
  - C.  $-0.6 \text{ m/s}^2$
  - D.  $-0.3 \text{ m/s}^2$
21. An object moves along the  $x$ -axis with a constant acceleration of  $6 \text{ m/s}^2$  and an initial velocity of  $-24 \text{ m/s}$ . It is located at  $x = 6 \text{ m}$  when  $t = 0 \text{ s}$ . What is its position when its velocity is zero?
- A. 6 m
  - B.  $-42 \text{ m}$
  - C.  $-90 \text{ m}$
  - D.  $-96 \text{ m}$
22. Which of the following is an action-reaction pair for a space station containing astronauts in orbit about the earth?
- A. the weight of the space station and the centripetal force on the space station
  - B. the weight of the astronauts and the centripetal force on the space station
  - C. the weight of the space station and the gravitational force of the space station on the earth
  - D. the weight of the astronauts and the gravitational force of the space station on the astronauts

23. A person who weighs  $w$  newtons stands on a scale in an elevator that is initially at rest. The elevator accelerates upward to a constant speed and then slows to a stop. Which of the following graphs best represents the reading on the scale?

A.

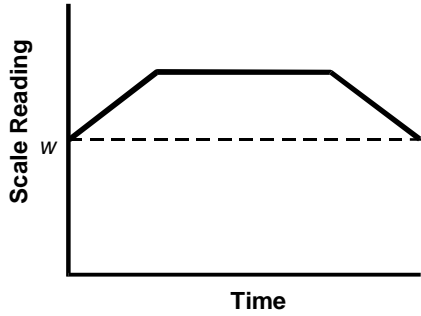

B.

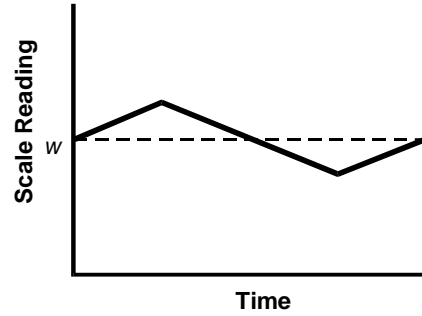

C.

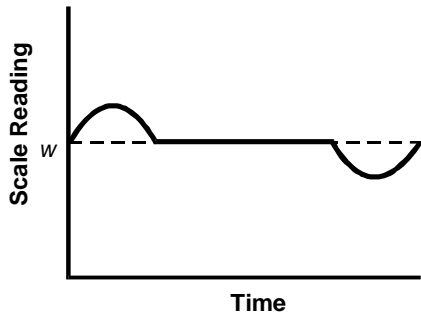

D.

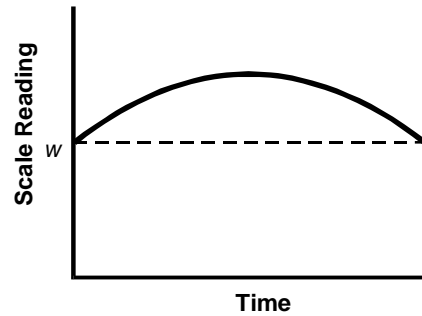

24. Use the diagram below to answer the question that follows.

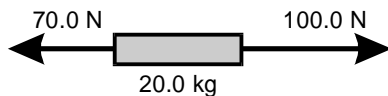

The diagram above shows the horizontal forces on a 20.0 kg mass. The forces are constant in time. If the mass starts from rest, how far has it traveled in the horizontal direction after 3.00 s?

- A. 4.50 m
- B. 6.75 m
- C. 9.00 m
- D. 25.5 m

25. Use the diagram below to answer the question that follows.

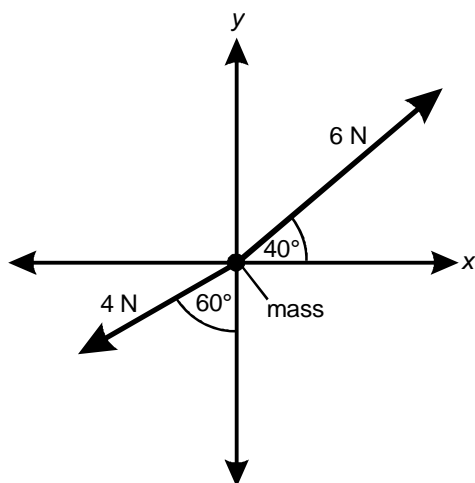



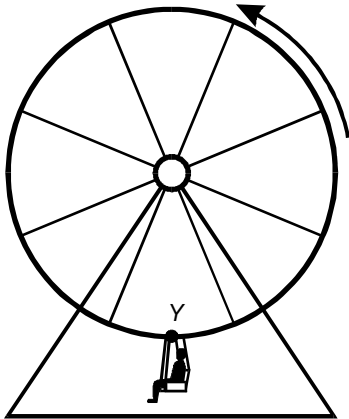

The free-body diagram above shows two forces acting on a mass. Which of the following equations represents the vector sum of the forces in newtons, in the  $x$ -direction?

- A.  $\Sigma F_x = -4 \cos 60^\circ + 6 \sin 40^\circ$
- B.  $\Sigma F_x = -4 \sin 60^\circ + 6 \sin 40^\circ$
- C.  $\Sigma F_x = -4 \cos 60^\circ + 6 \cos 40^\circ$
- D.  $\Sigma F_x = -4 \sin 60^\circ + 6 \cos 40^\circ$
26. The gravitational force between two masses is 80.0 N. Their centers are separated by a distance of  $6.40 \times 10^6$  m. What is the force if the distance is changed to  $12.8 \times 10^6$  m?
- A. 20.0 N
- B. 40.0 N
- C. 160 N
- D. 320 N
27. A 10 kg object is acted on by a net force that makes a  $50^\circ$  angle with the  $x$ -axis. The  $x$ -component of the force is 30 N. What is the magnitude of the acceleration of the mass?
- A.  $1.9 \text{ m/s}^2$
- B.  $2.3 \text{ m/s}^2$
- C.  $3.9 \text{ m/s}^2$
- D.  $4.7 \text{ m/s}^2$

28. Use the diagram below to answer the question that follows.



The diagram above represents a Ferris wheel rotating at a constant speed. Which of the following vectors represents the acceleration of a person on the wheel at point Y?

- A. 
- B. 
- C. 
- D. 

29. A satellite in a circular orbit travels at a speed  $v$  at a distance  $r$  above the center of the earth. If the satellite is boosted to a new orbital distance of  $2r$ , what will be its speed?

- A.  $0.5v$   
 B.  $0.7v$   
 C.  $1.4v$   
 D.  $2v$

30. Use the diagram below to answer the question that follows.

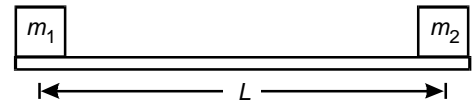

A light rod has masses attached to each end, as shown in the diagram above. At what distance from mass  $m_1$  will the rod be balanced in equilibrium?

- A.  $\frac{L}{2}$   
 B.  $\frac{m_1 L}{m_1 + m_2}$   
 C.  $\frac{m_2 L}{m_1 + m_2}$   
 D.  $\frac{L(m_1 + m_2)}{2(m_1 + m_2)}$

31. Use the diagram below to answer the question that follows.

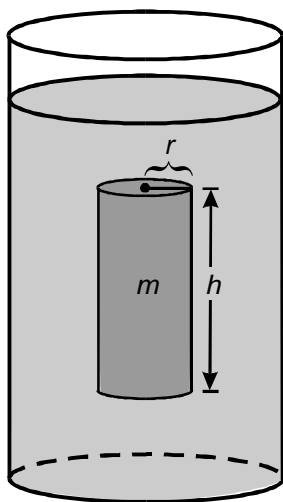

A right circular cylinder has a mass  $m$ , radius  $r$ , and a height  $h$ . The cylinder is completely submerged in a fluid of density  $\rho$ , as shown in the diagram above. What is the magnitude of the net force on the cylinder?

- A.  $\rho gh + mg$   
 B.  $\rho gh - mg$   
 C.  $\pi r^2 \rho gh + mg$   
 D.  $\pi r^2 \rho gh - mg$

32. A horizontal pipe has a diameter of 10.0 cm. Fluid flows in the pipe at 0.500 m/s. The pipe is attached to a smaller pipe that has a diameter of 4.00 cm. What is the speed of the fluid in the smaller pipe?

- A. 0.200 m/s  
 B. 1.25 m/s  
 C. 3.13 m/s  
 D. 12.5 m/s

33. An elevator with passengers has a total mass of 800 kg and moves a vertical distance of 20.0 m in 10.0 s. What is the average power expended in lifting this mass?

- A.  $1.57 \times 10^2$  W  
 B.  $1.57 \times 10^4$  W  
 C.  $1.57 \times 10^5$  W  
 D.  $1.57 \times 10^6$  W

34. Use the graph below to answer the question that follows.

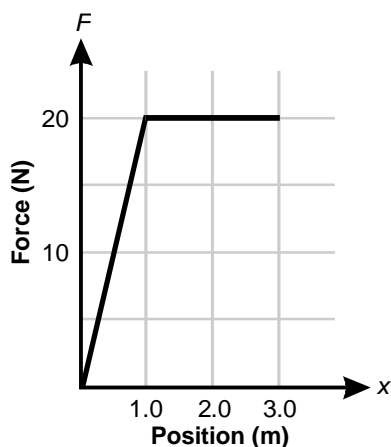

The graph above shows how the force on a mass depends on the position of the mass. What is the change in the kinetic energy of the mass as it moves from  $x = 0.0$  m to  $x = 3.0$  m?

- A. 0.0 J  
 B. 20 J  
 C. 50 J  
 D. 60 J
35. A mass is pulled 5.00 m across a smooth, horizontal surface by a force of magnitude 12.0 N. The force acts at an angle of  $60.0^\circ$  with the horizontal. What is the work done by the force?
- A. 24 J  
 B. 30 J  
 C. 52 J  
 D. 60 J

36. Use the diagram below to answer the question that follows.

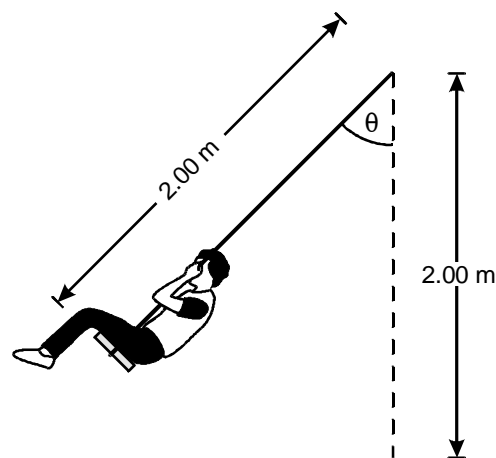

The length of each of the ropes on a playground swing is 2.00 m. What is the maximum speed attainable on the swing if the maximum value of  $\theta$  is  $45.0^\circ$ ?

- A. 1.41 m/s  
 B. 2.00 m/s  
 C. 3.39 m/s  
 D. 8.85 m/s
37. A box of books that weighs 40 N is dragged at a speed of 1.5 m/s across a rough floor. If the coefficient of friction between the floor and the box is 0.20, what is the rate at which heat energy is dissipated?
- A. 5.3 W  
 B. 12 W  
 C. 60 W  
 D. 300 W

38. Use the diagram below to answer the question that follows.

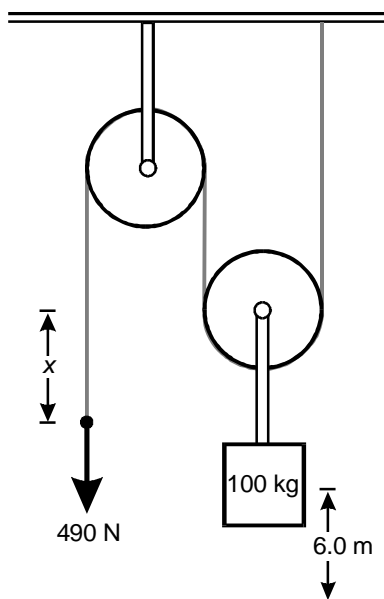

A person applies a force of 490 N over a distance  $x$  to lift a 100 kg mass 6.0 m. If the pulley system is 100% efficient, what is  $x$ ?

- A. 3.0 m
- B. 6.0 m
- C. 8.0 m
- D. 12 m

39. Use the graph below to answer the question that follows.

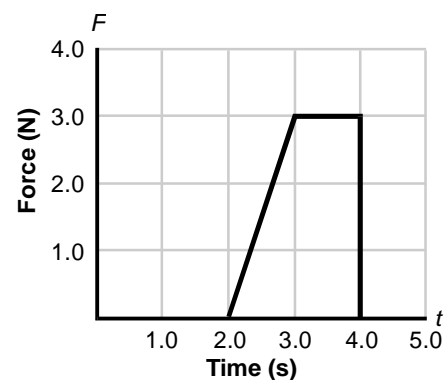

A 2.00 kg mass with an initial speed of 3.00 m/s moving in a straight line in the positive direction is acted on by the force shown in the graph above. What is the speed of the mass at  $t = 5.00$  s?

- A. 2.25 m/s
- B. 4.50 m/s
- C. 5.25 m/s
- D. 10.5 m/s

40. A ball of mass 15 g initially moving at a speed of 20 m/s is caught in a person's hand. If the average force exerted by the hand on the ball is 5.0 N, how long does it take for the ball to come to rest?
- A. 0.06 s  
 B. 0.15 s  
 C. 1.2 s  
 D. 1.5 s

41. Use the diagram below to answer the question that follows.

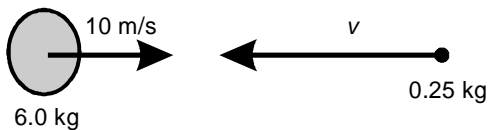

A 6.0 kg mass is moving to the right at 10 m/s. A 0.25 kg mass is fired toward the left at the larger mass. What speed ( $v$ ) must the smaller mass have to completely stop both masses?

- A. 4.2 m/s  
 B. 15 m/s  
 C. 150 m/s  
 D. 240 m/s

42. Use the diagram below to answer the question that follows.

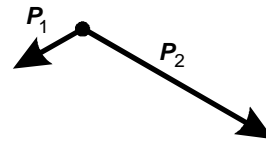

An object at rest in deep space explodes into three pieces. The momentum of two of the pieces is shown in the diagram above. Which of the following vectors best represents the momentum of the third piece?

A.



B.



C.

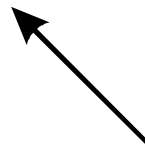

D.



43. The angular speed of a star spinning about its axis increases as the star begins to contract to a smaller radius. Which of the following quantities associated with the star must decrease as this occurs?

- A. moment of inertia
- B. angular momentum
- C. rotational kinetic energy
- D. net external torque

44. A person holds a spinning bicycle wheel while sitting stationary on a chair that is free to rotate about a vertical axis. As the person changes the axis of the spinning bicycle wheel, the chair begins to rotate about its axis. The chair's rotation is a result of:

- A. conservation of angular momentum.
- B. a torque due to the force of gravity.
- C. conservation of rotational kinetic energy.
- D. the mechanical advantage of double-axis rotational system.

45. Which of the following graphs shows how the average kinetic energy of the molecules depends on the absolute temperature of an ideal gas?

A.

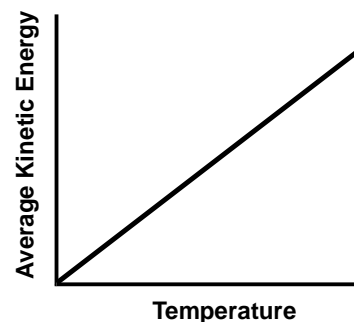

B.

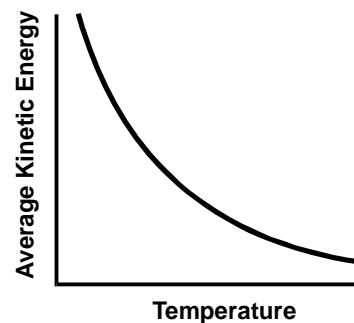

C.

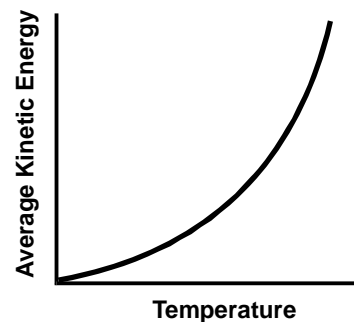

D.

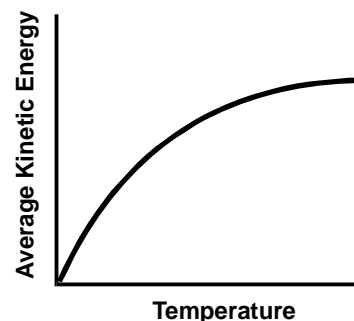

46. Which of the following describes the process by which energy is transmitted from one region of space to another through molecular collisions?

- A. radiation
- B. latent heat
- C. convection
- D. conduction

47. Use the graph below to answer the question that follows.

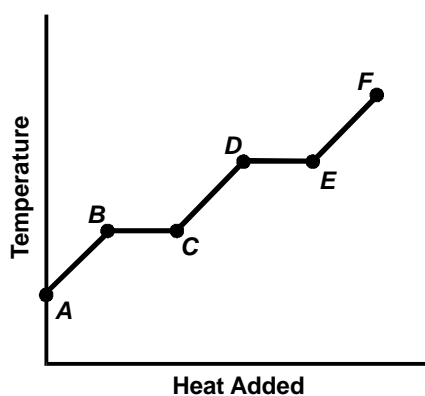

The graph above shows a heating curve for a substance. Which segment represents the transition from solid to liquid phase?

- A.  $AB$
- B.  $BC$
- C.  $CD$
- D.  $DE$

48. Use the diagram below to answer the question that follows.

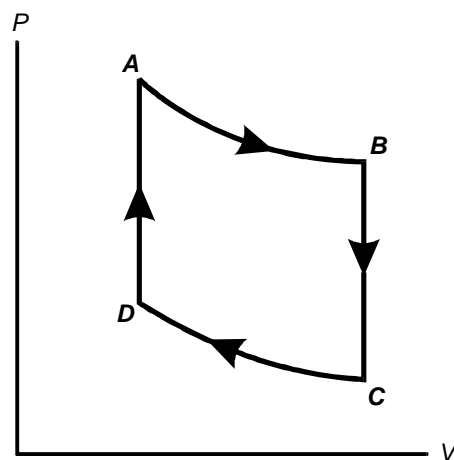

The diagram above represents the pressure ( $P$ ) and volume ( $V$ ) of an ideal gas. If  $AB$  is an isothermal process, which of the following must be true?

- A. No work is done in going from state  $A$  to state  $B$ .
- B. Curve  $AD$  represents an isobaric process.
- C. The product of the pressure and the volume is constant along  $AB$ .
- D. Curve  $CD$  represents an adiabatic process.

49. Which of the following best describes the microscopic interpretation of the concept of entropy?
- the distribution of energy per degree of freedom of a molecule
  - the amount of randomness or disorder in a system
  - the average time required for a system to reach equilibrium
  - the lowest temperature a quantum mechanical system can reach

50. On a dry winter day, a person walks across a carpet, reaches to touch a door-knob, and observes a spark about 3 mm long. Given that the dielectric breakdown of air is approximately 3 MV/m, which of the following is best estimate for the potential difference between the person's hand and the doorknob?

- 90 V
- 900 V
- 9,000 V
- 9,000,000 V

51. Use the diagram below to answer the question that follows.

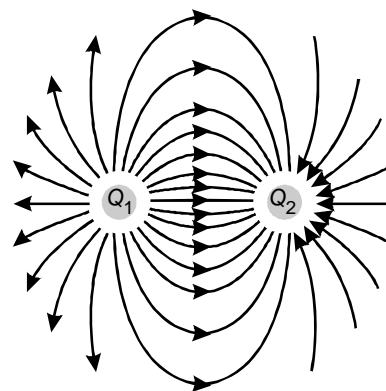

Given the electric field lines shown above, what are the charge pairs?

- $Q_1$  positive,  $Q_2$  positive
  - $Q_1$  positive,  $Q_2$  negative
  - $Q_1$  negative,  $Q_2$  positive
  - $Q_1$  negative,  $Q_2$  negative
52. Use the diagram below to answer the question the follows.

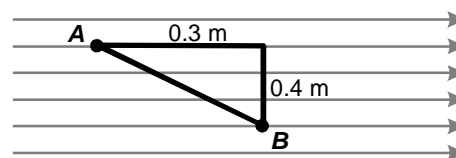

The diagram above shows an electric field of 10 N/C that is constant in magnitude and direction. What is the electrostatic potential between points A and B?

- 3 V
- 4 V
- 5 V
- 7 V

53. Use the diagram below to answer the question that follows.

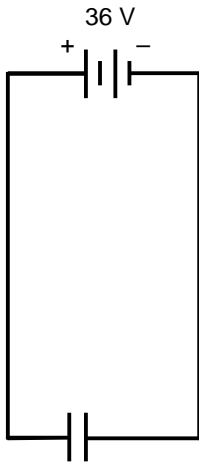

A 36 V battery is in series with a parallel plate capacitor, as shown in the diagram above. The plate separation is 0.20 m. The plates are large, so that the electric field is approximately constant between them. What is the magnitude and direction of the field?

- A. 7.2 N/C to the left
- B. 7.2 N/C to the right
- C. 180 N/C to the left
- D. 180 N/C to the right

54. Use the diagram below to answer the question that follows.

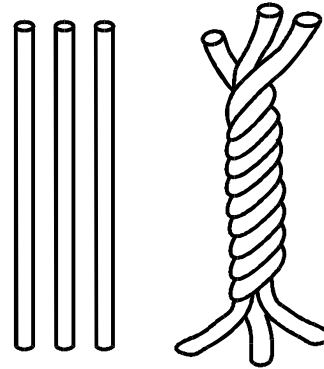

A piece of bare conducting wire of cross-sectional area  $A$  has a resistance  $R$ . If three identical pieces of the wire are twisted together as shown in the diagram above, the resistance will be closest to which of the following?

- A.  $\frac{1}{3}R$
- B.  $R$
- C.  $3R$
- D.  $9R$

55. Use the diagram below to answer the question that follows.

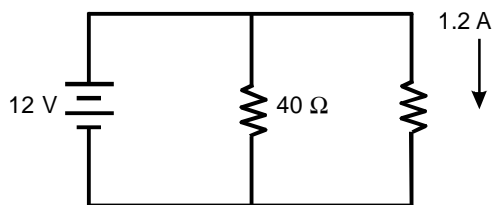

What is the current through the battery?

- A. 0.3 A
- B. 1.2 A
- C. 1.5 A
- D. 2.4 A

56. The wall adapter for recharging a cell phone battery draws 20 mA at 115 V. If left plugged in for 24 hours, how much energy will the device dissipate?

- A.  $1.5 \times 10^{-5}\ \text{kW}\cdot\text{h}$
- B.  $9.0 \times 10^{-4}\ \text{kW}\cdot\text{h}$
- C.  $5.5 \times 10^{-2}\ \text{kW}\cdot\text{h}$
- D.  $5.5 \times 10^{-1}\ \text{kW}\cdot\text{h}$

57. A 9.0 V battery has an internal resistance of about  $2.0\ \Omega$ . If the terminals of the battery are short-circuited, the battery gets hot. At approximately what rate is heat generated by the battery?

- A. 4.5 W
- B. 11 W
- C. 18 W
- D. 41 W

58. Use the diagram below to answer the question that follows.

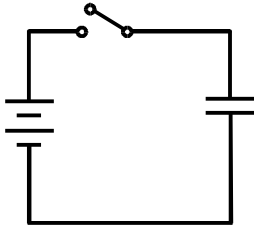

The capacitor is originally uncharged. When the switch is closed, which of the following represents the voltage across the capacitor?

A.

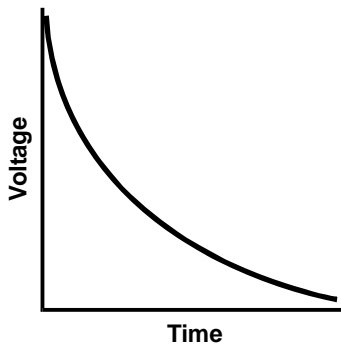

B.

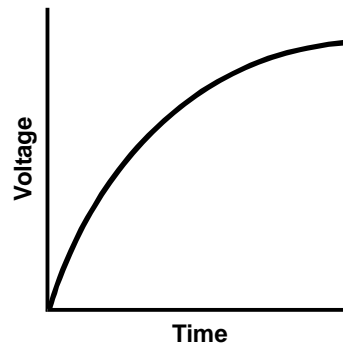

C.

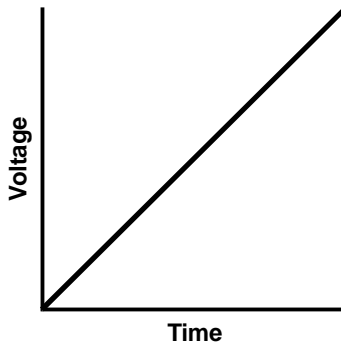

D.

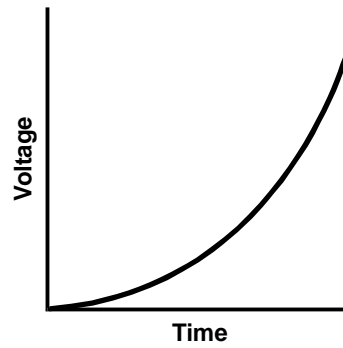

59. Use the diagram below to answer the question that follows.

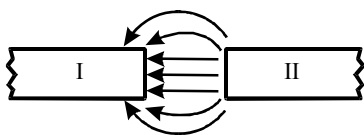

The diagram above shows the magnetic field between two magnetic poles. Which of the following correctly identifies the poles?

- A. I = S, II = S
- B. I = N, II = N
- C. I = N, II = S
- D. I = S, II = N
60. A circular loop of wire is connected in series with a voltage source  $V$  and a resistor  $R$ . The strength of the magnetic field in the middle of the loop is directly proportional to:
- A.  $VR$ .
- B.  $\frac{V}{R}$ .
- C.  $V^2R$ .
- D.  $\frac{V^2}{R}$ .

61. The force on a charged particle moving in a direction perpendicular to a magnetic field is 0.50 N. What is the force on the particle in the same field if the angle between the particle's velocity vector and the field is  $50^\circ$ ?
- A. 0.25 N
- B. 0.32 N
- C. 0.38 N
- D. 0.60 N
62. A wire coil of radius 2.0 cm with 10 turns is in a magnetic field of 2.0 T. The field is perpendicular to the plane of each turn of the coil. The coil is wired in series with a resistor of  $5.0 \Omega$ . The field drops at a constant rate to 0.0 T in 10 ms. What is the current through the resistor?
- A. 0.50 A
- B. 2.5 A
- C. 8.0 A
- D. 13 A

63. Use the diagram below to answer the question that follows.

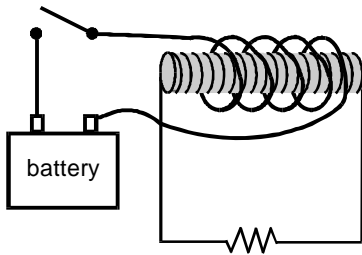

The diagram above shows an iron bar with two insulated coils of wire around the bar. The exterior coil is in series with a battery and a switch. The interior coil is in series with a resistor. The switch is originally open. Which of the following describes what happens to the current through the resistor when the switch is closed?

- A. It will spike to some value and quickly drop to zero.
- B. It will slowly build up to a constant value.
- C. It will instantaneously jump to a constant value.
- D. It will oscillate just above and below a nonzero value.

64. According to Maxwell's equations, a time-dependent magnetic field will be produced under which of the following circumstances?
- A. The total magnetic flux through a surface is equal to zero.
  - B. A field exists that is the gradient of a scalar function.
  - C. An electric field varies with time.
  - D. The electric flux through surface is zero.

65. Which of the following can be concluded about a region of space where the rate of change of the magnetic field is nonzero?
- A. An electric field will be produced.
  - B. A harmonic electromagnetic wave will be produced.
  - C. Electromagnetic waves in the visible spectrum will be produced.
  - D. A magnetic material is present in the vicinity of the region.

66. Use the information below to answer the question that follows.

A pendulum swings back and forth. Due to frictional forces, the amplitude of motion decreases each cycle until the pendulum eventually comes to a stop.

Which of the following circuits behaves in a manner analogous to the system described above?

A.

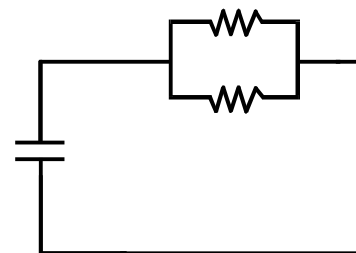

B.

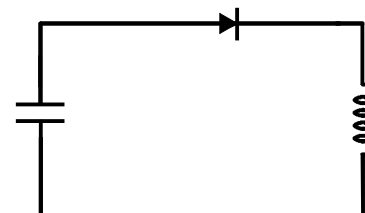

C.

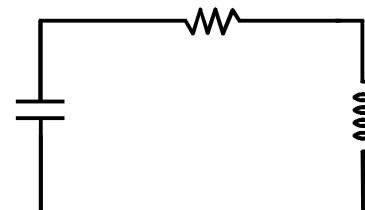

D.

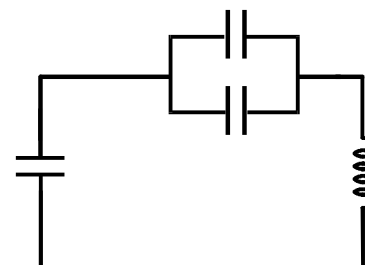

67. Use the diagram below to answer the question that follows.

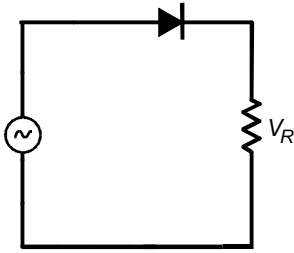

The input signal for the ideal circuit above is a sine wave. Which of the following graphs shows the voltage ( $V_R$ ) across the resistor with respect to time ( $t$ )?

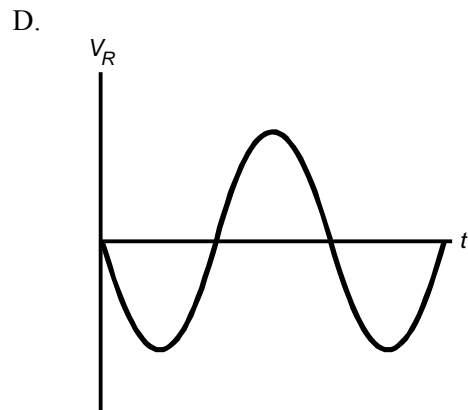
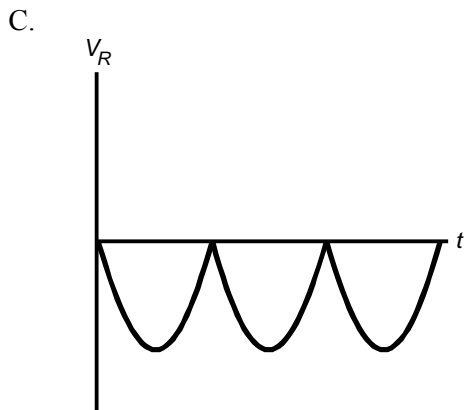
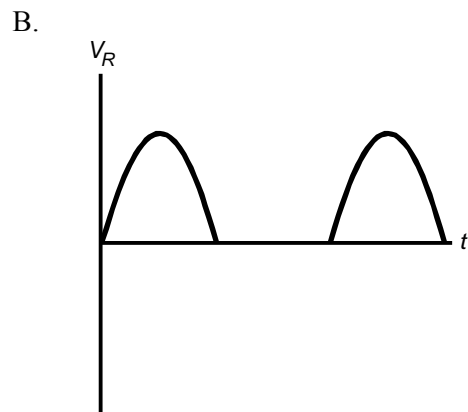
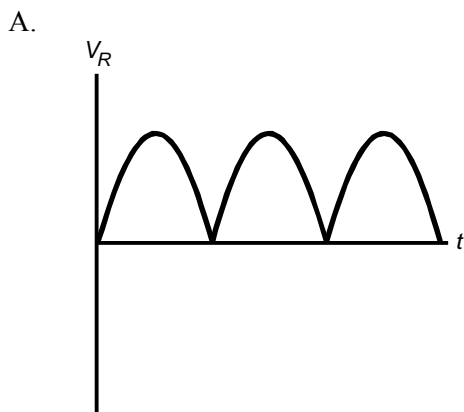

68. A transducer is used to convert mechanical vibrations into electrical waves. The power output of the transducer is of the order of several microwatts. A scientist would like to increase this value so the signal can be recorded to magnetic tape. A circuit based primarily on which of the following components would be most appropriate for this purpose?

A. capacitors  
 B. diodes  
 C. transformers  
 D. transistors

69. Use the graph below to answer the question that follows.

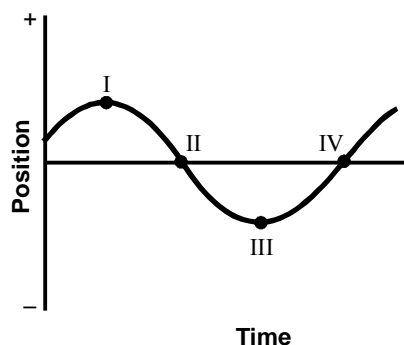

The position versus time graph above represents a mass undergoing simple harmonic motion. At which of the following positions is the net force on the mass in the positive direction and maximum in magnitude?

A. I  
 B. II  
 C. III  
 D. IV

70. Use the graph below to answer the question that follows.

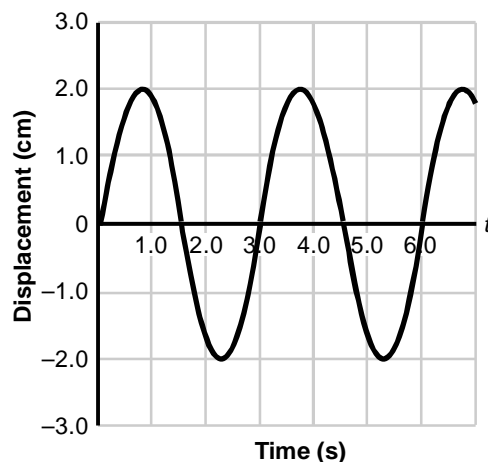

The graph above gives the displacement of a pendulum bob with respect to time. What is the length of the pendulum?

A. 0.74 m  
 B. 1.5 m  
 C. 2.2 m  
 D. 3.0 m

71. The speed of sound in air is 340 m/s. At what pitch must a 170-cm-tall person sing to produce a sound wave with a wavelength equal to the person's height?
- A. 24.5 Hz  
 B. 200 Hz  
 C. 255 Hz  
 D. 578 Hz

72. Use the diagram below to answer the question that follows.

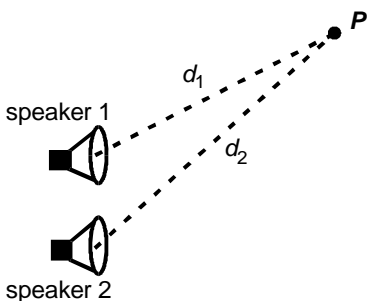

The two loudspeakers shown in the diagram above are in phase and produce a sound of frequency 680 Hz. The speed of sound is 340 m/s. At point  $P$ , no sound is heard. Given that  $d_1$  and  $d_2$  are the distances from  $P$  to speaker 1 and speaker 2, respectively, which of the following equations could be true?

- A.  $d_2 - d_1 = \frac{1}{4}$  m
- B.  $d_2 - d_1 = \frac{1}{2}$  m
- C.  $d_2 - d_1 = 2$  m
- D.  $d_2 - d_1 = 3$  m

73. A harmonic sound wave at a point  $x$  and time  $t$  is represented as a pressure wave by the following equation:

$$P(x, t) = P \cos(kx - \omega t + \phi)$$

Which of the following quantities associated with the sound wave is most closely related to the human perception of pitch?

- A.  $P$
- B.  $k$
- C.  $\omega$
- D.  $\phi$

74. A piece of string, fixed at both ends, is struck to produce a wave in the string. Given that  $\mu$  is the string's linear mass density and  $T$  is its tension, which of the following combinations of values will produce the greatest wave speed?

- A.  $\mu = 0.1$  kg/m,  $T = 0.1$  N
- B.  $\mu = 0.1$  kg/m,  $T = 1.0$  N
- C.  $\mu = 1.0$  kg/m,  $T = 0.1$  N
- D.  $\mu = 1.0$  kg/m,  $T = 1.0$  N

75. An organ pipe is closed at one end. As the temperature of the gas inside the pipe increases, which of the following will also increase?

- A. the wavelength of the fundamental frequency
- B. the ratio of the harmonics produced in the pipe
- C. the speed of the waves produced in the pipe
- D. the number of overtones produced in the pipe

76. Use the diagram below to answer the question that follows.

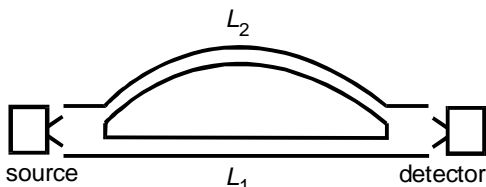

A source produces a sound wave of frequency  $f$  with a wavelength of 1.0 m. The sound travels to a detector through two different paths of lengths  $L_1$  and  $L_2$ . The sound intensity at the detector will be at its maximum when which of the following is true?

- A.  $L_2 - L_1 = 0.25$  m
- B.  $L_2 - L_1 = 0.50$  m
- C.  $L_2 - L_1 = 1.5$  m
- D.  $L_2 - L_1 = 2.0$  m

77. Use the diagram below to answer the question that follows.

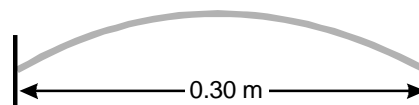

The diagram above shows a string of length 0.30 m oscillating in its first harmonic. What is the wavelength when the string is oscillating in its third harmonic?

- A. 0.10 m
- B. 0.20 m
- C. 0.45 m
- D. 0.90 m

78. Which of the following electric circuits could be used to generate electromagnetic waves of a given frequency  $f$ ?

A.



B.

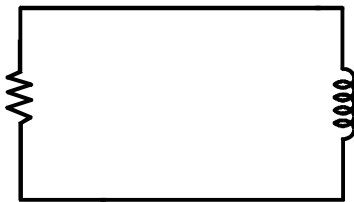

C.



D.

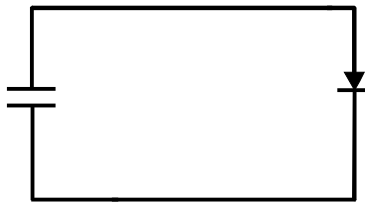

79. Use the diagram below to answer the question that follows.

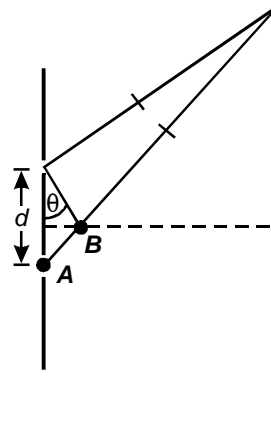

The diagram above shows the geometry for a double-slit interference pattern produced by light from a laser that is incident on two slits separated by a distance  $d$ . For small values of  $\theta$ , which of the following best describes the significance of the length of segment  $AB$  in the diagram?

- A. It is equal to an integral multiple of the wavelength of the incident laser light.
- B. It is directly proportional to the intensity of a bright region in the pattern.
- C. It is equal to the distance between any two adjacent bright fringes on the screen.
- D. It is related to the difference in phase between the two light waves arriving at a point on the screen.

80. A solar panel is 12% efficient at converting sunlight into electrical energy. On average, the sunlight that strikes the earth's surface has an intensity of  $250 \text{ W/m}^2$ . Which of the following is the best estimate for the size of a solar panel needed to provide 1.2 kW of energy to a home?

- A.  $5 \text{ m} \times 8 \text{ m}$   
 B.  $6 \text{ m} \times 10 \text{ m}$   
 C.  $13 \text{ m} \times 13 \text{ m}$   
 D.  $20 \text{ m} \times 20 \text{ m}$

81. Use the table below to answer the question that follows.

Frequency of Electromagnetic Waves (Hz)	
infrared	$10^{12}$
ultraviolet	$10^{15}$
X-ray	$10^{18}$
gamma	$10^{23}$

The table above gives the approximate frequency of some electromagnetic waves. Which of following wavelengths should be used for penetrating radiation designed to produce medical images?

- A.  $10^{-3} \text{ m}$   
 B.  $10^{-6} \text{ m}$   
 C.  $10^{-9} \text{ m}$   
 D.  $10^{-12} \text{ m}$

82. Use the diagram below to answer the question that follows.

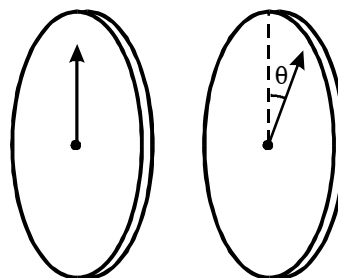

Light is incident on the first polarizing filter. As the second filter is rotated, at what angles will the intensity of the transmitted light be a minimum?

- A.  $45^\circ, 90^\circ$   
 B.  $45^\circ, 225^\circ$   
 C.  $90^\circ, 180^\circ$   
 D.  $90^\circ, 270^\circ$

83. Use the diagram below to answer the question that follows.

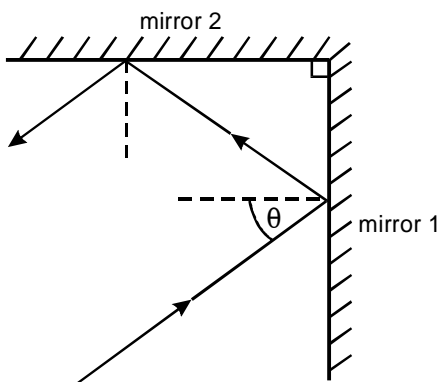

The diagram above shows two mirrors attached at a right angle. A ray of light is incident on one mirror with an angle of incidence of  $\theta$ . What is the angle of reflection from the second mirror?

- A.  $\frac{1}{2}\theta$
  - B.  $\theta$
  - C.  $90 - \theta$
  - D.  $180 - 2\theta$
84. A ray of light passes from air ( $n = 1.0$ ) into a material. The angle of incidence is  $40^\circ$  and the angle of refraction is  $25^\circ$ . What is the index of refraction of the material?
- A. 0.66
  - B. 0.85
  - C. 1.2
  - D. 1.5

85. Use the diagram below to answer the question that follows.

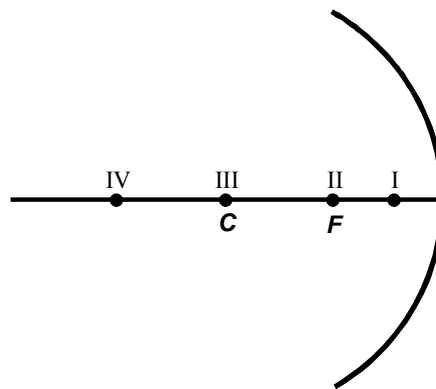

The diagram above shows a concave mirror with focal point  $F$  and center of curvature  $C$ . An object placed at which of the following positions in front of the concave mirror will produce a magnified, virtual image?

- A. I
  - B. II
  - C. III
  - D. IV
86. A converging lens produces a real image at a distance of 20 cm for an object located 40 cm in front of the lens. What is the focal length of the lens?
- A. 0.50 cm
  - B. 2.5 cm
  - C. 13 cm
  - D. 20 cm

87. An ideal gas is in a container. In a time interval  $\Delta t$ ,  $n$  particles with momentum  $p$  in the  $x$ -direction undergo elastic collisions with the wall of the container. The area of the wall is  $A$ . Which of the following expressions is equal to the average pressure on the wall?
- A.  $\frac{np}{A\Delta t}$
- B.  $\frac{2np}{A\Delta t}$
- C.  $\frac{2np\Delta t}{A}$
- D.  $\frac{np\Delta t}{A}$
88. Which of the following describes the primary significance of Rutherford's alpha-scattering experiments?
- A. They developed the concept of the half-life of a radioactive element.
- B. They created new radioactive isotopes by nuclear bombardment.
- C. They changed one atomic element into another through nuclear reactions.
- D. They demonstrated the existence of a small, dense, positively charged atomic nucleus.
89. The energy levels of the hydrogen atom are given by the equation below.
- $$E_n = \frac{-13.6}{n^2} \text{ eV}$$
- What is the energy of a photon released when an electron transitions from the  $n = 3$  level to the  $n = 1$  level?
- A. 4.53 eV
- B. 1.51 eV
- C. 12.1 eV
- D. 15.1 eV
90. Which of the following is one of Einstein's postulates of special relativity?
- A. Events that are simultaneous for one observer are not simultaneous for another observer in motion relative to the first.
- B. The energy of a photon is directly proportional to the frequency of the light.
- C. The momentum of an object approaches infinity as its speed approaches that of light.
- D. The speed of light in a vacuum has the same value in all inertial reference frames.

91. An elementary particle moving at  $0.99c$  with respect to the laboratory frame has a half-life of  $16 \mu\text{s}$  in the laboratory frame. What is the half-life of the particle in its own frame of reference?
- A.  $0.50 \mu\text{s}$   
 B.  $2.3 \mu\text{s}$   
 C.  $4.0 \mu\text{s}$   
 D.  $15 \mu\text{s}$
92. The work function for potassium metal is  $2.2 \text{ eV}$ . If  $h$  is Planck's constant, what is the minimum frequency of light required to remove an electron from potassium metal?
- A.  $\frac{2.2}{h}$   
 B.  $\frac{h}{2.2}$   
 C.  $2.2h$   
 D.  $h^{2.2}$
93. Which of the following expressions gives the de Broglie wavelength of an electron of mass  $m$  and kinetic energy  $E$ ?
- A.  $\frac{h}{\sqrt{2mE}}$   
 B.  $h\sqrt{2mE}$   
 C.  $\frac{\sqrt{2E}}{mh}$   
 D.  $mh\sqrt{2E}$
94. If  $\psi(x)$  is a solution to the one-dimensional, time-independent Schrödinger equation, which of the following is proportional to the probability of finding an electron in a region  $\Delta x$ ?
- A.  $\sqrt{\psi(x)}$   
 B.  $\int |\psi(x)|^2 dx$   
 C.  $\int \psi(x) dx$   
 D.  $i\hbar \frac{d\psi(x)}{dx}$
95. The hydrogen atom in the ground state has a radius of approximately  $0.53 \times 10^{-10} \text{ m}$  and an ionization energy of  $13.6 \text{ eV}$ . To "see" a hydrogen atom, light with a wavelength of the same order of magnitude of the size of the atom must be used. Which of the following statements describes how a photon corresponding to this wavelength will interact with the hydrogen atom?
- A. The photon will have little effect on the ground-state energy of the electron.  
 B. The photon will have enough energy to transition the electron to a slightly higher energy level.  
 C. The photon will have just enough energy to completely ionize the hydrogen atom.  
 D. The photon will have an energy of several orders of magnitude greater than the ionization energy.

96. A system consists of 3 electrons. The electrons have spin of either  $\frac{1}{2}$  or  $-\frac{1}{2}$  and energy quantum numbers of either  $n = 1$  or  $n = 2$ . Which of the following explains why one electron must have an energy corresponding to  $n = 2$ ?
- Compton effect
  - Meissner effect
  - Pauli exclusion principle
  - Heisenberg uncertainty principle
97. The chemical symbol for sodium is  ${}_{11}^{23}\text{Na}$ . How many electrons does the ion  $\text{Na}^{+2}$  have?
- 9
  - 13
  - 21
  - 25
98. The half-life of  ${}^{90}\text{Sr}$  is 27.7 years. Approximately how long will it take for a sample consisting of  $10^6$  strontium-90 atoms to decay to  $10^3$  strontium-90 atoms?
- 30 years
  - 110 years
  - 280 years
  - 730 years
99. Which of the following best describes why temperatures of the order of  $10^8$  K are necessary for a fusion reaction to occur?
- The reactants must be stripped of all electrons to form a plasma before they can fuse together.
  - The reactants must be separated into nucleons before the reaction can take place.
  - The reactants must be confined in a strong magnetic field produced by thermally active nucleons.
  - The reactants must have sufficient kinetic energy to overcome the Coulomb barrier.
100. Which of the following is a significant advantage of using radioactive tracers in nuclear medicine?
- The radiation passes through the less dense matter such as skin and muscle and is absorbed by denser material such as bone.
  - The physiological function of organs can be studied by following the movement of a radioisotope through the organ.
  - The radioactive tracers emit high-energy particles that can be used to destroy malignant tumors.
  - No ionization energy is released during the use of tracers since the imaging equipment measures the perturbed magnetic field of the water molecules in the body.

## DIRECTIONS FOR THE OPEN-RESPONSE ITEM ASSIGNMENTS

This section of the test consists of two open-response item assignments that appear on the following pages. You will be asked to prepare a written response of approximately 1–2 pages for each assignment. You should use your time to plan, write, review, and edit your response for each assignment.

For each assignment, read the topic and directions carefully before you begin to work. Think about how you will organize your response. You may use any blank space in this test booklet to make notes, write an outline, or otherwise prepare your response.

As a whole, your response to each assignment must demonstrate an understanding of the knowledge of the field. In your response to each assignment, you are expected to demonstrate the depth of your understanding of the subject area by applying your knowledge rather than by merely reciting factual information.

Your response to each assignment will be evaluated based on the following criteria.

- **PURPOSE:** the extent to which the response achieves the purpose of the assignment
- **SUBJECT KNOWLEDGE:** appropriateness and accuracy in the application of subject knowledge
- **SUPPORT:** quality and relevance of supporting evidence
- **RATIONALE:** soundness of argument and degree of understanding of the subject area

The open-response item assignments are intended to assess subject knowledge. Your responses must be communicated clearly enough to permit valid judgment of the evaluation criteria by scorers. Your responses should be written for an audience of educators in this field. The final version of each response should conform to the conventions of edited American English. Your responses should be your original work, written in your own words, and not copied or paraphrased from some other work.

Be sure to write about the assigned topics. Please write legibly. You may not use any reference materials during the test. Remember to review your work and make any changes you think will improve your responses.

Write or print your response in the space provided following the assignment.

**OPEN-RESPONSE ITEM ASSIGNMENT #1**

**Use the information below to complete the exercise that follows.**

A high school physics teacher would like to create a classroom activity to investigate the conservation of linear momentum in a collision.

Prepare a response in which you:

- briefly describe the purpose of the investigation and the data to be collected;
- describe the equipment and the procedure used to collect the data; and
- describe how to analyze the data and how the data relate to the purpose of the investigation.

Your response may include diagrams, tables, and/or graphs.





**OPEN-RESPONSE ITEM ASSIGNMENT #2**

**Use the information below to complete the exercise that follows.**

The intensity of the electromagnetic radiation reaching the upper atmosphere of the earth is  $1.4 \text{ kW/m}^2$ . The mean distance between the sun and the earth is  $1.5 \times 10^{11} \text{ m}$ , and the radius of the earth is  $6.4 \times 10^6 \text{ m}$ .

Prepare a response in which you:

- determine the rate at which electromagnetic energy is incident on the earth's surface, disregarding the effect of the earth's atmosphere;
- determine the rate at which the sun produces electromagnetic energy; and
- find the rate, in kilograms per second, at which the mass of the sun is being converted into electromagnetic energy.

Be sure to explain your reasoning and show your work. Your response may include diagrams, tables, and/or graphs.





## **PRACTICE TEST RESULTS**

## PRACTICE TEST RESULTS OVERVIEW

The practice test provides valuable information regarding your preparedness for the MTEL Physics (11) test. In this section, you will find information and tools to help you determine your preparedness on the various sections of the test.

### Multiple-Choice Questions

A Multiple-Choice Question Answer Key Worksheet is provided to assist you in evaluating your multiple-choice responses. The worksheet contains five columns. The first column indicates the multiple-choice question number, the second column indicates the objective to which the test question was written, and the third column indicates the correct response. The remaining columns are for your use in calculating the number of multiple-choice questions you answered correctly or incorrectly.

An Evaluation Chart for the multiple-choice questions is also provided to help you assess which content covered by the test objectives may require additional study.

### Open-Response Items

Evaluation Information, Sample Responses and Analyses, as well as a Scoring Rubric are provided for these items. You may wish to refer to this information when evaluating your practice test responses.

### Total Test

Practice Test Score Calculation information is provided to help you estimate your score on the practice test. Although you cannot use this practice test to precisely predict how you might score on an official MTEL Physics (11) test, you may be able to determine your degree of readiness to take an MTEL test at an operational administration. No passing score has been determined for the practice test.

**MULTIPLE-CHOICE QUESTION  
ANSWER KEY WORKSHEET**

Question Number	Objective Number	Correct Response	Your Response	
			Correct?	Incorrect?
1	0001	B		
2	0001	B		
3	0001	D		
4	0002	C		
5	0002	B		
6	0002	A		
7	0003	B		
8	0003	C		
9	0003	D		
10	0004	C		
11	0004	A		
12	0004	C		
13	0005	C		
14	0005	A		
15	0005	D		
16	0006	C		
17	0006	B		
18	0006	C		
19	0006	B		
20	0006	B		
21	0006	B		
22	0007	C		
23	0007	C		
24	0007	B		
25	0007	D		
26	0007	A		
27	0007	D		
28	0008	A		
29	0008	B		
30	0008	C		
31	0008	D		
32	0008	C		
33	0009	B		
34	0009	C		

**MULTIPLE-CHOICE QUESTION  
ANSWER KEY WORKSHEET (continued)**

Question Number	Objective Number	Correct Response	Your Response	
			Correct?	Incorrect?
35	0009	B		
36	0009	C		
37	0009	B		
38	0009	D		
39	0010	C		
40	0010	A		
41	0010	D		
42	0010	C		
43	0010	A		
44	0010	A		
45	0011	A		
46	0011	D		
47	0011	B		
48	0011	C		
49	0011	B		
50	0012	C		
51	0012	B		
52	0012	A		
53	0012	D		
54	0013	A		
55	0013	C		
56	0013	C		
57	0013	D		
58	0013	B		
59	0014	D		
60	0014	B		
61	0014	C		
62	0014	A		
63	0014	A		
64	0015	C		
65	0015	A		
66	0015	C		
67	0015	B		
68	0015	D		

**MULTIPLE-CHOICE QUESTION  
ANSWER KEY WORKSHEET (continued)**

Question Number	Objective Number	Correct Response	Your Response	
			Correct?	Incorrect?
69	0016	C		
70	0016	C		
71	0016	B		
72	0016	A		
73	0017	C		
74	0017	B		
75	0017	C		
76	0017	D		
77	0017	B		
78	0018	A		
79	0018	D		
80	0018	A		
81	0018	C		
82	0018	D		
83	0019	C		
84	0019	D		
85	0019	A		
86	0019	C		
87	0020	B		
88	0020	D		
89	0020	C		
90	0020	D		
91	0020	B		
92	0021	A		
93	0021	A		
94	0021	B		
95	0021	D		
96	0021	C		
97	0022	A		
98	0022	C		
99	0022	D		
100	0022	B		

**Count the number of multiple-choice questions you answered correctly:**

\_\_\_\_\_ of 100 multiple-choice questions

**MULTIPLE-CHOICE QUESTION  
PRACTICE TEST EVALUATION CHART**

In the evaluation chart that follows, the multiple-choice questions are arranged in numerical order and by test objective. Check your responses against the correct responses provided to determine how many questions within each objective you answered correctly.

**Subarea I: Nature of Science**

<b>Objective 0001: Understand the nature of scientific inquiry and scientific processes.</b>	
1B___ 2B___ 3D___	___/3

<b>Objective 0002: Understand the processes of gathering, organizing, analyzing, and reporting scientific data.</b>	
4C___ 5B___ 6A___	___/3

<b>Objective 0003: Understand scientific tools, instruments, materials, and safety practices used in physics demonstrations and investigations.</b>	
7B___ 8C___ 9D___	___/3

<b>Objective 0004: Understand the historical and contemporary relationships among science, technology, and society.</b>	
10C___ 11A___ 12C___	___/3

<b>Objective 0005: Understand the use of mathematics in physics.</b>	
13C___ 14A___ 15D___	___/3

**Subarea I (Objectives 0001–0005) Total \_\_\_/15**

**MULTIPLE-CHOICE QUESTION  
PRACTICE TEST EVALUATION CHART (continued)**

**Subarea II: Force and Motion**

**Objective 0006: Understand concepts related to motion in one and two dimensions.**

16C \_\_\_ 17B \_\_\_ 18C \_\_\_ 19B \_\_\_ 20B \_\_\_ 21B \_\_\_      \_\_\_/6

**Objective 0007: Understand Newton's laws of motion.**

22C \_\_\_ 23C \_\_\_ 24B \_\_\_ 25D \_\_\_ 26A \_\_\_ 27D \_\_\_      \_\_\_/6

**Objective 0008: Understand characteristics of uniform circular motion, rotational dynamics,  
and fluid mechanics.**

28A \_\_\_ 29B \_\_\_ 30C \_\_\_ 31D \_\_\_ 32C \_\_\_      \_\_\_/5

Subarea II (Objectives 0006–0008) Total \_\_\_/17

**Subarea III: Energy, Momentum, and Heat Transfer**

**Objective 0009: Understand the concepts of energy, work, and power and the principle  
of conservation of energy.**

33B \_\_\_ 34C \_\_\_ 35B \_\_\_ 36C \_\_\_ 37B \_\_\_ 38D \_\_\_      \_\_\_/6

**Objective 0010: Understand the conservation of linear momentum and angular momentum.**

39C \_\_\_ 40A \_\_\_ 41D \_\_\_ 42C \_\_\_ 43A \_\_\_ 44A \_\_\_      \_\_\_/6

**Objective 0011: Understand heat transfer and the principles of thermodynamics.**

45A \_\_\_ 46D \_\_\_ 47B \_\_\_ 48C \_\_\_ 49B \_\_\_      \_\_\_/5

Subarea III (Objectives 0009–0011) Total \_\_\_/17

**MULTIPLE-CHOICE QUESTION  
PRACTICE TEST EVALUATION CHART (continued)**

**Subarea IV: Electricity and Magnetism**

<b>Objective 0012: Understand principles of electrostatics.</b>	
50C___ 51B___ 52A___ 53D___	___/4

<b>Objective 0013: Understand characteristics of electric current and electric circuits.</b>	
54A___ 55C___ 56C___ 57D___ 58B___	___/5

<b>Objective 0014: Understand magnetic fields and electromagnetic induction.</b>	
59D___ 60B___ 61C___ 62A___ 63A___	___/5

<b>Objective 0015: Understand applications of electromagnetism and electronics.</b>	
64C___ 65A___ 66C___ 67B___ 68D___	___/5

**Subarea IV (Objectives 0012–0015) Total \_\_\_/19**

**MULTIPLE-CHOICE QUESTION  
PRACTICE TEST EVALUATION CHART (continued)**

**Subarea V: Waves, Sound, and Light**

**Objective 0016: Understand oscillations, waves, and wave motion.**

69C \_\_\_ 70C \_\_\_ 71B \_\_\_ 72A \_\_\_ \_\_\_\_\_/4

**Objective 0017: Understand the characteristics of sound waves and the basic principles of acoustics.**

73C \_\_\_ 74B \_\_\_ 75C \_\_\_ 76D \_\_\_ 77B \_\_\_ \_\_\_\_\_/5

**Objective 0018: Understand characteristics of electromagnetic waves.**

78A \_\_\_ 79D \_\_\_ 80A \_\_\_ 81C \_\_\_ 82D \_\_\_ \_\_\_\_\_/5

**Objective 0019: Understand the principles of lenses and mirrors.**

83C \_\_\_ 84D \_\_\_ 85A \_\_\_ 86C \_\_\_ \_\_\_\_\_/4

**Subarea V (Objectives 0016–0019) Total \_\_\_\_\_/18**

**Subarea VI: Modern Physics**

**Objective 0020: Understand the atomic nature of matter and the basic principles of special relativity.**

87B \_\_\_ 88D \_\_\_ 89C \_\_\_ 90D \_\_\_ 91B \_\_\_ \_\_\_\_\_/5

**Objective 0021: Understand the basic principles of quantum theory.**

92A \_\_\_ 93A \_\_\_ 94B \_\_\_ 95D \_\_\_ 96C \_\_\_ \_\_\_\_\_/5

**Objective 0022: Understand the principles of radioactivity and characteristics of nuclear reactions.**

97A \_\_\_ 98C \_\_\_ 99D \_\_\_ 100B \_\_\_ \_\_\_\_\_/4

**Subarea VI (Objectives 0020–0022) Total \_\_\_\_\_/14**

## OPEN-RESPONSE ITEM EVALUATION INFORMATION

### How Open-Response Items Are Scored

Open-response items are scored through a process called focused holistic scoring. Scorers judge the overall effectiveness of the response rather than individual aspects considered in isolation. Scorer judgments are based on the quality of the response, not on length or neatness. Responses must be long enough to cover the topic adequately and scorers must be able to read what is written.

### How to Evaluate Your Practice Responses

On the following pages, you will find two "strong" and two "weak" sample responses. PLEASE DO NOT REVIEW THE SAMPLE RESPONSES UNTIL AFTER YOU HAVE WRITTEN YOUR OWN RESPONSE. When you do review the two "strong" and "weak" sample responses and analyses included here, please note the following points:

- ✓ For the purposes of the practice test, responses are identified as "strong" or "weak" rather than given a score point of 1–4.
- ✓ The responses identified as "strong" may contain flaws; however, these responses do demonstrate the performance characteristics of a "strong response."
- ✓ The two "strong" responses demonstrate the examinees' appropriate understanding and application of the subject matter knowledge. However, these responses do not necessarily reflect the full range of "correct answers" that would demonstrate an understanding of the subject matter.
- ✓ The "Analysis" accompanying each "strong" and "weak" response discusses the main attributes of the responses, but does not identify all flaws or strengths that may be present.

Compare your practice responses to the [Sample Responses](#) to determine whether your responses are more similar to the strong or weak responses. Also review the [Analyses](#) on those pages and the [Scoring Rubric](#) to help you better understand the characteristics of strong and weak responses. This evaluation will help you identify specific problems or weaknesses in your practice responses. Further information on scoring can be found in the [Test Information Booklet](#) and Faculty Guide at [www.mtel.nesinc.com](http://www.mtel.nesinc.com) and at [www.doe.mass.edu/mtel](http://www.doe.mass.edu/mtel); select "FAQ," then "After the Test."

**OPEN-RESPONSE ITEM  
SCORING RUBRIC, SAMPLE RESPONSES, AND ANALYSES**

**Massachusetts Tests for Educator Licensure®  
SCORING RUBRIC FOR SUBJECT TESTS**

**Performance Characteristics:**

Purpose	The extent to which the response achieves the purpose of the assignment.
Subject Matter Knowledge	Accuracy and appropriateness in the application of subject matter knowledge.
Support	Quality and relevance of supporting details.
Rationale	Soundness of argument and degree of understanding of the subject matter.

**Scoring Scale:**

<b>Score Point</b>	<b>Score Point Description</b>
<b>4</b>	<p><b>The "4" response reflects a thorough knowledge and understanding of the subject matter.</b></p> <ul style="list-style-type: none"> <li>• The purpose of the assignment is fully achieved.</li> <li>• There is a substantial, accurate, and appropriate application of subject matter knowledge.</li> <li>• The supporting evidence is sound; there are high-quality, relevant examples.</li> <li>• The response reflects an ably reasoned, comprehensive understanding of the topic.</li> </ul>
<b>3</b>	<p><b>The "3" response reflects an adequate knowledge and understanding of the subject matter.</b></p> <ul style="list-style-type: none"> <li>• The purpose of the assignment is largely achieved.</li> <li>• There is a generally accurate and appropriate application of subject matter knowledge.</li> <li>• The supporting evidence is adequate; there are some acceptable, relevant examples.</li> <li>• The response reflects an adequately reasoned understanding of the topic.</li> </ul>
<b>2</b>	<p><b>The "2" response reflects a limited knowledge and understanding of the subject matter.</b></p> <ul style="list-style-type: none"> <li>• The purpose of the assignment is partially achieved.</li> <li>• There is a limited, possibly inaccurate or inappropriate, application of subject matter knowledge.</li> <li>• The supporting evidence is limited; there are few relevant examples.</li> <li>• The response reflects a limited, poorly reasoned understanding of the topic.</li> </ul>
<b>1</b>	<p><b>The "1" response reflects a weak knowledge and understanding of the subject matter.</b></p> <ul style="list-style-type: none"> <li>• The purpose of the assignment is not achieved.</li> <li>• There is little or no appropriate or accurate application of subject matter knowledge.</li> <li>• The supporting evidence, if present, is weak; there are few or no relevant examples.</li> <li>• The response reflects little or no reasoning about or understanding of the topic.</li> </ul>
<b>U</b>	<b>The response is unrelated to the assigned topic, illegible, primarily in a language other than English, not of sufficient length to score, or merely a repetition of the assignment.</b>
<b>B</b>	<b>There is no response to the assignment.</b>

**FIRST SAMPLE WEAK RESPONSE FOR OPEN-RESPONSE  
ITEM ASSIGNMENT #1**

The purpose of this experiment is to show that the momentum always gets transferred from one object to another whenever two objects collide.

Use two matchbox cars. Find the mass of the cars. Put one car on a ramp and measure how high it is. Then let the car roll down from the ramp and crash into the other car. Measure how far the second car rolls after the collision.

To analyze the data, use the formula  $mgh$  where  $h$  is the height of the first car on the ramp and  $g = 9.8 \text{ m/s}^2$  (from the formula page). Show that  $mgh$  of the first car equals  $mv$  of the second car, since all of the momentum of the first car goes to the second car. Show that  $v = gh$ , since the masses of the two cars are the same and cancel from the equation. This can be calculated since you know both  $g$  and  $h$ . Graph the data to show that the momentum is exchanged.

## ANALYSIS FOR FIRST WEAK RESPONSE TO OPEN-RESPONSE ITEM ASSIGNMENT #1

*This is an example of a weak response because it is characterized by the following:*

**Purpose:** Although an attempt is made to address the bulleted prompts, the purpose of the assignment is not achieved because the response contains numerous inaccuracies. The response to the bulleted prompt about the purpose of the investigation is not a statement of the conservation of momentum. While the procedure is adequate, the data to be collected is insufficient for even determining the final velocity of the car. Also, the data analysis confuses energy and momentum.

**Subject Matter Knowledge:** A weak understanding of the subject matter is evidenced. The candidate understands that the momentum of the second car is given by the product of mass and velocity, but does not provide an appropriate experimental method for determining its velocity. Simply measuring the distance the second car travels after the collision is not sufficient. The response also suggests that the velocity of the second car can be calculated from the expression  $mgh$ , but this quantity refers to the potential energy of the first car, which is not equal to the momentum of the second car. Furthermore, the response seems to state that all of the momentum of the first car will always be transferred to the second car, which is not true. It is also unclear how to graph the data. In general, the response indicates a lack of understanding of not only concepts related to momentum, but also the basic features of a scientific experiment.

**Support:** Some support is provided. With some modifications the description of the procedure could be used to meet the purpose of the investigation. There is, however, no discussion of how to use the distance the second car rolls after the collision. Furthermore, the discussion of how to calculate the momentum of the second car does not make sense, especially since it is the value that one would expect to measure. Also, the statement that for the second car  $v = gh$  lacks supporting details—it is unclear what is being calculated and what is being measured. Finally, there are no supporting details on how to graph the data (e.g., labeling axes, independent versus dependent variables, plotting points).

**Rationale:** There is a limited rationale provided throughout the response and the logical reasoning is weak. For example, during the data analysis section of the experiment the students are supposed to "show that  $v = gh$ , since the masses of the two cars are the same and cancel from the equation." This tends to indicate that somehow they are supposed to measure  $v$  from the experiment and show that it is equal to  $gh$ . However, in the next sentence they are told that "this can be calculated since you know both  $g$  and  $h$ ." It is unclear exactly what the candidate is saying; this appears to be an example of circular reasoning. Furthermore, at the very end of the response, there is no rationale for why the data should be graphed, nor any discussion of how the graph might relate to the purpose of the investigation.

## SECOND SAMPLE WEAK RESPONSE FOR OPEN-RESPONSE ITEM ASSIGNMENT #1

This demonstration will show that momentum is conserved in a linear manner in a collision.

Get 50 dominoes and line them up in a straight line about 1/2 inch apart. Carefully tap the first domino and time how long it takes all 50 to fall. Use a stopwatch to time how long it takes. Next, line up the 50 dominoes about 3/4 inch apart, making sure they are in a straight line. Carefully tap the first domino time how long it takes all 50 to fall. Next, line up the 50 dominoes about 1 inch apart and repeat the process.

This shows that energy can be passed in a linear way when one domino collides into the next, so it is conserved. It should take the same amount of time to transmit the energy each time, which can be seen by comparing the times. This is a good hands-on activity that students will enjoy doing.

## ANALYSIS FOR SECOND WEAK RESPONSE TO OPEN-RESPONSE ITEM ASSIGNMENT #1

*This is an example of a weak response because it is characterized by the following:*

**Purpose:** The purpose of the assignment is partially achieved. While the response presents an interesting activity and indicates some understanding of the design of a scientific investigation, it is off-topic. The investigation does not use the equipment and procedures to generate data about the conservation of linear momentum in a collision. The conclusions it draws from the data are therefore irrelevant to the given exercise.

**Subject Matter Knowledge:** Subject matter knowledge is weak. While the response indicates an understanding of dependent and independent variables, conveys the need to record time as a variable, and indicates some understanding of the transfer of energy, the proposed experiment is not designed to measure conservation of linear momentum. There is no indication that the candidate understands what momentum is or the measurements that need to be made to find the momentum of a particle, let alone to investigate the conservation of momentum.

**Support:** The only supporting evidence provided is that energy is passed from one domino to the next as they collide. This is unrelated to the exercise, since there is no discussion of how momentum might play a role in the investigation provided.

**Rationale:** The response is poorly reasoned. It begins by purporting to describe an experiment that shows momentum is conserved in a collision and proposes an experiment that is somewhat related to momentum, but it makes no connection between the experiment and momentum, nor the conservation of momentum. Also, given the experiment, there is no discussion of why the amount of time for the dominoes to fall might be independent of the distance between the dominoes. The conclusion is inconsistent with the purpose of the proposed investigation due to confusion between energy and momentum.

## FIRST SAMPLE STRONG RESPONSE FOR OPEN-RESPONSE ITEM ASSIGNMENT #1

The purpose of this experiment is to investigate a two-dimensional collision between two objects using the conservation of linear momentum. Students must find the mass of the objects to be used, and because momentum is a vector quantity, they must calculate the initial and final components of the velocities of each of the objects.

A toy air hockey table along with two plastic hockey pucks will be used to do this experiment. The use of an air hockey table will reduce friction and generate more accurate results. Data on the trajectories of the pucks before and after the collision will be collected by holding a video camera over the air hockey table. A stopwatch and a meterstick will also be needed.

First students should find the mass of each puck and record it in a table. Next students will need to create a x-y coordinate system on the air hockey table by selecting a convenient origin. They can mark a grid on the table using thin tape or washable marker. Puck #2 should be placed at the origin, and puck #1 placed on the table a distance away. The coordinates of the centers of the pucks should be recorded. One student can gently strike puck #1 with the meterstick, aiming it at puck #2, while a second student records the collision using the video camera. Students can take turns doing several trials.

Because momentum is a vector quantity, students will need to determine both the horizontal and vertical speeds of each puck before and after the collision. This can be done by replaying the videotape over several times and carefully determining where and when the two pucks strike the edge of the hockey table after the collision. Students can then use  $v_x = \Delta x / \Delta t$  and  $v_y = \Delta y / \Delta t$  to determine the necessary components of the velocities. Using  $p = mv$ , students can investigate the relationships below. Note that the initial momentum of puck #2 = 0.

$$P_{\text{initial}x1} = P_{\text{final}x1} + P_{\text{final}x2}$$

$$P_{\text{initial}y1} = P_{\text{final}y1} + P_{\text{final}y2}$$

If the data is collected and analyzed properly, it should show that momentum is a vector quantity and that the initial momentum in the x-direction equals the final momentum in the x-direction and the initial momentum in the y-direction equals the final momentum in the y-direction.

---

## ANALYSIS FOR FIRST STRONG RESPONSE TO OPEN-RESPONSE ITEM ASSIGNMENT #1

*This is an example of a strong response because it is characterized by the following:*

**Purpose:** The purpose of the assignment is fully achieved, as the candidate responds to each bulleted prompt. The response describes the purpose of the investigation, addresses the equipment and procedure appropriate for collecting the data, and offers an accurate explanation of how to analyze the data to investigate the conservation of linear momentum in a two-dimensional collision.

**Subject Matter Knowledge:** The response demonstrates accurate and appropriate subject matter knowledge. Noting that the mass of each puck and the initial and final components of the velocity of each puck are quantities that need to be measured shows a strong understanding of the vector nature of momentum. Selecting an air hockey table to minimize the effects of friction indicates that the candidate is aware of the need to reduce experimental error. The use of a coordinate system and a video camera provides a reliable method for collecting the data. Finally, the description of how to analyze the momentum in the  $x$ - and  $y$ -directions before and after the collision clearly shows that the candidate understands the vector nature of the conservation of momentum and its application in a laboratory setting.

**Support:** The candidate provides a detailed account of how the experiment is to be carried out in terms of the data to be collected (mass, velocity components), and the tools to use (meterstick, stopwatch, air hockey table, video camera). The experimental procedure is clearly described and includes a discussion of the actions each student should perform. An explanation of how the initial and final momentum of each puck is to be determined from the videotape is logical, and the final description of how to demonstrate conservation of momentum is clear and easy to follow.

**Rationale:** The entire response follows a pattern in which a justification is provided for each statement made by the candidate. For example, the candidate states that the components of the velocities need to be determined because "momentum is a vector quantity" and that an air hockey table is used in order to "reduce friction." Also, the introduction of a coordinate system drawn on the table is later connected to finding the initial and final momentum of the particles. Finally, a well-reasoned explanation of the vector nature of momentum is provided along with a description of how it is related to the data collected.

**SECOND SAMPLE STRONG RESPONSE FOR OPEN-RESPONSE  
ITEM ASSIGNMENT #1**

Purpose: To demonstrate the conservation of linear momentum ( $p = mv$ ) in a collision.

Data: Mass of objects, distance traveled, time to travel the distance.

Equipment: air track, two carts with magnets (or double duct tape) attached to each so that the carts stick together when they collide. A meterstick, 3 stopwatches.

Procedure: Find the mass of each cart. Measure the length of the track. Make sure air track is level. Place cart A in the middle of the air track. Put cart B at one end of the track. Have student 1 give cart B a push so it rolls into cart A. Make sure they stick together. Have student 2 record the time it takes for cart A to hit cart B. Have student 3 record the time it takes for the combined carts to hit the other end of the track. Repeat several times.

Analysis: Momentum =  $mv$ , and it's conserved, so

momentum before = momentum after

$$M_A v_A + M_B v_B = M_A v_{Af} + M_B v_{Bf}$$

but  $v_B$  before = 0 and because they stick together,  $v_{Af} = v_{Bf}$

$$M_A v_A = (M_A + M_B) v_f$$

Find  $v_i$  before the collision by using  $\Delta x / \Delta t_i$ . Find  $v_f$  after the collision using  $v_f = \Delta x / \Delta t_2$  where  $\Delta x$  is half the length of the cart and  $\Delta t_i$  and  $\Delta t_2$  are the times measured by student 2 and student 3, respectively.

Momentum before should equal momentum after.

---

## ANALYSIS FOR SECOND STRONG RESPONSE TO OPEN-RESPONSE ITEM ASSIGNMENT #1

*This is an example of a strong response because it is characterized by the following:*

**Purpose:** The response addresses all of the bulleted prompts in the assignment. The purpose of the investigation and the data to be collected are described. The equipment to be used and the experimental procedure to be followed are all explained in a clear and concise manner. A well-reasoned mathematical discussion of how to analyze the data is provided, along with a statement linking the data analysis to the purpose of the investigation.

**Subject Matter Knowledge:** The response indicates strong subject matter knowledge. The candidate accurately describes what data needs to be collected and proposes a procedure that is elegant in its approach. Using an air track reduces friction. Placing one cart at the end of the track and the other in the middle facilitates measuring distances and times. Having the two carts stick together during the collision facilitates the momentum computations that need to be performed. These features are likely to reduce experimental error. The data analysis at the end is accurate and demonstrates a clear understanding of the conservation of momentum and its application to the experimental investigation described.

**Support:** Enough support is provided so that the entire response is clear and easy to follow. For example, two mechanisms are suggested for having the carts stick together. The importance of having the carts stick together is also emphasized. The initial placements of the carts on the track along with the procedure for having the different students record the various time intervals is described in detail. The analysis of the momentum follows a clear sequence of steps and several supporting statements are included. A final statement relating the calculations to the purpose of the investigation is provided.

**Rationale:** The response is well organized. Each bulleted prompt is addressed, and justifications for each statement become apparent while reading from the top of the response to the bottom. For example, the justification for placing one cart in the middle of the track and the other at the end of the track becomes clear in the discussion computing the initial and final velocities. The same is true of the justification for having the carts stick together during the collision. In addition, rationales for the simplifying mathematical steps in the data analysis section are provided (e.g., "but  $v_B$  before = 0 and because they stick together,  $v_{Af} = v_{Bf}$ ").

**FIRST SAMPLE WEAK RESPONSE FOR OPEN-RESPONSE  
ITEM ASSIGNMENT #2**

The intensity of the radiation of the earth can be found as follows:

$$\pi(R) \times 1.4 \text{ kW/m}^2 =$$

$$(3.14 \times 6.4 \times 10^6 \times 1.4) =$$

$$28.13 \times 10^6 \text{ W}$$

The energy produced by the sun can be found as follows:

$$\pi(R) = (3.14 \times 1.5 \times 10^8 \text{ m}) = 4.71 \times 10^8 \text{ W}$$

The rate is the intensity and the speed can be found as follows:

$$R = I \times S$$

$$(28.13 \times 10^6 \times 3.0 \times 10^8) =$$

$$84.39 \times 10^{14} \text{ Kg/s}$$

**ANALYSIS FOR FIRST WEAK RESPONSE TO OPEN-RESPONSE  
ITEM ASSIGNMENT #2**

*This is an example of a weak response because it is characterized by the following:*

**Purpose:** The purpose of the assignment is partially achieved. The candidate has a vague understanding of the methods used in answering the first two bulleted prompts, but there are serious errors in the solution presented. The response to the third prompt makes little sense.

**Subject Matter Knowledge:** There is limited subject matter knowledge demonstrated. While the formulas used to answer bullets 1 and 2 are related to concepts associated with circles, in the context of the problem, they are not correct. Little attention is paid to units and, given the values used in each calculation, the answers are not dimensionally correct. There is also a failure to convert from kW to W. The response to the third bullet is vague and it is not clear how it is related to the given prompt. Furthermore, the candidate does not make the connection between the production of electromagnetic radiation from the sun and the conversion of mass to energy.

**Support:** Although the calculations are clearly written, there is little support given for why a particular formula or calculation was used. Also, since units used in each step are not properly followed throughout the calculations, the computations are not supported using dimensional analysis.

**Rationale:** Given the response, there is no evidence that the candidate understands what the assignment is asking. The candidate makes no effort to restate the given information in his or her words and does not appear to understand what is given nor what is being asked. For example, in answering the first bullet, the diameter of the earth is multiplied by 1.4 kW/m<sup>2</sup>, but there is little discussion on why this might be a proper course of action. Overall, the response lacks any kind of a coherent problem-solving strategy.

## SECOND SAMPLE WEAK RESPONSE FOR OPEN-RESPONSE ITEM ASSIGNMENT #2

Incident on earth's surface is

$$\pi(R_e)^2 \times 1.4 \text{ kW/m}^2$$

$$3.14 \times (6.4)^2 \times 1.4 \text{ kW/m}^2$$

$$3.14 \times 40.96 \times 1.4$$

$$180.0 \times 10^6 = P$$

Energy produced by sun is

$$\frac{4}{3}\pi(R_s)^3 =$$

$$\frac{4}{3}\pi \times (1.5 \times 10^8)^3 =$$

$$\frac{4}{3}\pi \times (3.37 \times 10^{24}) = 14.13 \times 10^{24}$$

$E = mc^2$  so

$$m = \frac{E}{c^2} = \frac{14.13 \times 10^{24}}{(3.0 \times 10^8)^2} = \frac{14.13 \times 10^{24}}{6 \times 10^{16}}$$

$$m = 2.35 \times 10^8$$

## ANALYSIS FOR SECOND WEAK RESPONSE TO OPEN-RESPONSE ITEM ASSIGNMENT #2

*This is an example of a weak response because it is characterized by the following:*

**Purpose:** The purpose of the assignment is partially achieved. While some correct formulas and steps are taken, there are multiple errors and omissions.

**Subject Matter Knowledge:** Some knowledge is demonstrated in response to bullet 1. The correct formula is written, and the general approach to solving the problem is correct. However, the candidate does not copy the correct value for the radius of the earth into the response and therefore gets an incorrect answer. In response to bullet 2, the candidate uses the formula for the volume of a sphere instead of the surface area, and does not use the information provided ( $1.4 \text{ kW/m}^2$ ). This demonstrates a lack of conceptual understanding of the rate of change of energy per square meter. The candidate also incorrectly adds the exponents when finding the value for  $r^3$ . While an understanding of the equivalence of mass and energy is displayed in the response to bullet 3, the candidate fails to demonstrate understanding of the concept of power as the time rate of change of energy. Furthermore, the candidate has difficulty performing calculations using scientific notation.

**Support:** Some support is provided. The equations are written clearly and the work (though incorrect) is easy to follow. However, units are used inconsistently and in some cases the numbers are just strung together in a way that obscures their physical significance.

**Rationale:** There is little rationale provided in the response. There is no attempt to analyze the given information, nor to determine what the assignment is asking for. The failure to pay attention to units throughout the response tends to indicate that that candidate is guessing at a solution strategy rather than applying physics concepts. Answers are given without any units, showing a lack of attention to the importance of dimensional analysis in evaluating the reasonableness of a solution to a problem.

## FIRST SAMPLE STRONG RESPONSE FOR OPEN-RESPONSE ITEM ASSIGNMENT #2

The number  $1.4 \text{ kW/m}^2$  means that, ignoring the effects of the atmosphere, each square meter of the earth's surface that is facing the sun and is perpendicular to the sun's rays receives energy at the rate of  $1,400 \text{ J/s}$ . This is equal to the amount of energy striking a circular cross-section of the earth, or a circle whose radius is equal to the radius of the earth, since only half of the earth's surface faces the sun. Therefore, to determine the rate of electromagnetic energy incident on the earth's surface given the above data,

$$\pi(R_E)^2 \times 1.4 \text{ kW/m}^2 \text{ or}$$

$$3.14 (6.4 \times 10^6 \text{ m})^2 \times 1.4 \text{ kW/m}^2 \text{ or}$$

$$3.14 (40.96 \times 10^{12} \text{ m}^2) \times 1.4 \times 10^3 \text{ W/m}^2 \text{ or}$$

$$180,060 \times 10^{12} \text{ W or } 1.80 \times 10^{17} \text{ W}$$

To find the total rate of energy produced by the sun, note that at the surface of the earth, energy arrives at a rate of  $1,400 \text{ J/s}$  per square meter. Hence, each square meter of a sphere of radius equal to the earth-sun distance and centered at the sun receives energy at the rate of  $1,400 \text{ J/s}$ . From the formula pages, the surface area of a sphere =  $4\pi r^2$ . Therefore, the total power,  $P$ , is

$$P = 4\pi(R_S)^2(1.4 \times 10^3 \text{ W/m}^2)$$

$$P = (4)(3.14)(1.5 \times 10^{11} \text{ m})^2 (1.4 \times 10^3 \text{ W/m}^2)$$

$$P = 3.96 \times 10^{26} \text{ J/s}$$

The sun generates energy through the process of nuclear fusion. These nuclear reactions convert mass directly into energy. The relationship between mass and energy is given by Einstein's equation  $E = mc^2$ .

$$\text{Since } P = \frac{\Delta E}{\Delta t}$$

$$\text{then } \frac{\Delta E}{\Delta t} = \frac{\Delta mc^2}{\Delta t} \text{ where } c = \text{speed of light} = 3.0 \times 10^8 \text{ m/s}$$

$$\frac{\Delta m}{\Delta t} = \frac{P}{c^2} = \frac{3.96 \times 10^{26} \text{ J/s}}{(3.0 \times 10^8 \text{ m/s})^2} = \frac{3.96 \times 10^{26} \text{ J/s}}{9 \times 10^{16} \text{ m}^2/\text{s}^2}$$

$$\frac{\Delta m}{\Delta t} = 0.44 \times 10 \times 10^{10} \text{ kg/s} = 4.4 \times 10^9 \text{ kg/s}$$

This means that during the process of nuclear fusion in the sun, over 4 billion kilograms of matter is being converted directly into electromagnetic radiation each second.

## ANALYSIS FOR FIRST STRONG RESPONSE TO OPEN-RESPONSE ITEM ASSIGNMENT #2

*This is an example of a strong response because it is characterized by the following:*

**Purpose:** The purpose of the assignment is completely achieved. Each bulleted prompt is addressed and accurately answered. The candidate outlines the major approach for responding to each prompt and arrives at accurate answers. All answers are given using the correct units.

**Subject Matter Knowledge:** The examinee demonstrates a strong understanding of the subject matter knowledge. For example, the candidate correctly interprets the given information ( $1.4 \text{ kW/m}^2$ ) and the units used to measure it. The candidate next selects the correct formulas to find the power in bullets 1 and 2. The candidate then demonstrates an understanding of the process by which sun generates power and relates that process to Einstein's equation relating mass and energy. Finally, the candidate relates the concepts of power, energy, and mass and accurately calculates the final answer.

**Support:** The candidate offers strong support in responding to each bulleted prompt. A clear and appropriate explanation of the problem and its solution is given for each prompt. The correct equations are written clearly with appropriate numerical values, as appropriate. The major steps in each calculation are clearly shown, and the numerical calculations are written in a logical chain that is easy to follow. Attention is paid to the proper use of units.

**Rationale:** The candidate provides a strong rationale for the approach used in each bulleted prompt. Prior to performing any calculation, the candidate briefly outlines the problem-solving strategy. A justification of why the strategy is appropriate is also provided. This outline is then followed during the mathematical part of the solution. The candidate also adds a brief interpretation of the numerical answer at the end of the exercise.

## SECOND SAMPLE STRONG RESPONSE FOR OPEN-RESPONSE ITEM ASSIGNMENT #2

We have the following picture.

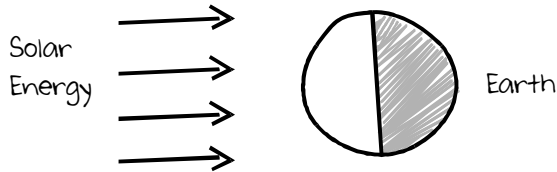

Since energy arrives at  $1.4 \text{ kW/m}^2$ , the amount striking the earth is  $1.4 \text{ kW/m}^2 \cdot \text{Area of earth's cross-section}$

$$\begin{aligned} (1400 \text{ J/s}\cdot\text{m}^2) \times \pi R_E^2 &= (1400 \text{ J/s}\cdot\text{m}^2) \times 3.14 \times 6.4 \times 10^6 \text{ m}^2 \\ &= (1400 \text{ J/s}\cdot\text{m}^2) \times 3.14 \times 4.1 \times 10^{13} \text{ m}^2 \\ &= 1.8 \times 10^{17} \text{ J/s because the square meters cancel.} \end{aligned}$$

For the sun we have the following picture.

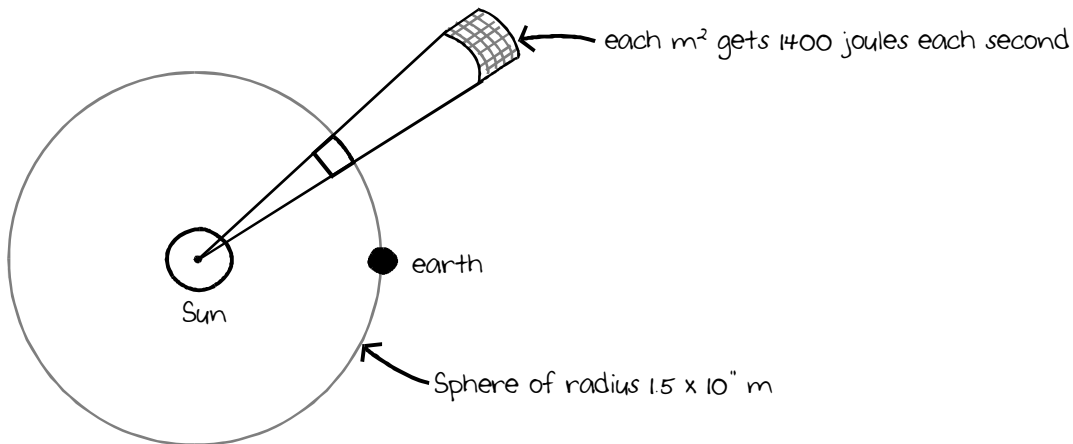

So the sun emits  $1400 \text{ J/s}\cdot\text{m}^2 \times \text{surface area of earth-sun sphere}$

$$(1400 \text{ J/s}\cdot\text{m}^2) \times 4\pi (1.5 \times 10^8 \text{ m})^2 = 4.0 \times 10^{26} \text{ J/s}$$

In stars, energy comes from mass converted to energy by  $E = mc^2$ .

$$\frac{E}{\Delta t} = \frac{mc^2}{\Delta t} = 4.0 \times 10^{26} \text{ J/s, so}$$

$$\frac{m}{\Delta t} = \frac{4.0 \times 10^{26} \text{ J/s}}{(3.0 \times 10^8 \text{ m/s})^2} = 4.4 \times 10^9 \text{ kg/s}$$

## ANALYSIS FOR SECOND STRONG RESPONSE TO OPEN-RESPONSE ITEM ASSIGNMENT #2

*This is an example of a strong response because it is characterized by the following:*

**Purpose:** The purpose of the assignment is completely achieved. Each bulleted prompt is addressed and accurately answered. Appropriate diagrams are used in the responses. All answers are given using the correct units.

**Subject Matter Knowledge:** A strong understanding of the subject matter knowledge is demonstrated for each bulleted prompt. The diagrams show the essential features of the physical situation in the first two prompts. Appropriate formulas related to the diagrams are then used to calculate answers to the problems. Finally, the relationship among mass and energy and power as the rate of change of energy is used to find the rate at which mass in the sun is converted to energy. All calculations are carried out correctly. Attention is paid to the proper use of units.

**Support:** Strong support is provided in responding to each bulleted prompt. Each diagram provides visual support for the calculations that follow. For example, in the first bullet, the candidate's diagram helps support the use of the area of a circle in finding the rate of energy incident on the earth's surface. The candidate also outlines the steps taken using words along with the given numerical values. The major numerical steps in each calculation are clearly shown and are easy to follow.

**Rationale:** The diagrams representing each physical problem demonstrate that the candidate understands what is given and what needs to be determined. These diagrams provide a strong rationale for the steps taken in the response. For example, the small expanded section in the second diagram gives a visual explanation of why the total power produced by the sun can be found by multiplying  $1.4 \text{ kW/m}^2$  by the surface area of a sphere of radius equal to the earth-sun distance. Also, the derivation of the formula for finding the rate of change of mass is clear and logical.

## PRACTICE TEST SCORE CALCULATION

The practice test score calculation is provided so that you may better gauge your performance and degree of readiness to take an MTEL test at an operational administration. Although the results of this practice test may be used as one indicator of potential strengths and weaknesses in your knowledge of the content on the official test, it is not possible to predict precisely how you might score on an official MTEL test.

The Sample Responses and Analyses for the open-response items may help you determine whether your responses are more similar to the strong or weak samples. The Scoring Rubric can also assist in estimating a score for your open responses. You may also wish to ask a mentor or teacher to help evaluate your responses to the open-response questions prior to calculating your total estimated score.

### How to Calculate Your Practice Test Score

Review the directions in the sample below and then use the blank practice test score calculation worksheet on the following page to calculate your estimated score.

#### SAMPLE

<b>Multiple-Choice Section</b>	
Enter the total number of multiple-choice questions you answered correctly:	<u>72</u>
Use Table 1 below to convert that number to the score and write your score in <b>Box A</b> :	<b>A:</b> <input style="width: 50px; text-align: center;" type="text" value="194"/>

<b>Open-Response Section</b>	
Enter the number of points (1 to 4) for your first open-response question:	<u>4</u>
Enter the number of points (1 to 4) for your second open-response question:	<u>3</u>
Add those two numbers (Number of open-response question points):	===== 7
Use Table 2 below to convert that number to the score and write your score in <b>Box B</b> :	<b>B:</b> <input style="width: 50px; text-align: center;" type="text" value="52"/>

<b>Total Practice Test Score (Estimated MTEL Score)</b>	
Add the numbers in <b>Boxes A and B</b> for an estimate of your MTEL score:	<b>A + B =</b> <input style="width: 50px; text-align: center;" type="text" value="246"/>

Practice Test Score Calculation Worksheet: Physics

Table 1:

Number of Multiple-Choice Questions Correct	Estimated MTEL Score	Number of Multiple-Choice Questions Correct	Estimated MTEL Score
0 to 25	108	61 to 65	177
26 to 30	117	66 to 70	185
31 to 35	125	71 to 75	194
36 to 40	134	76 to 80	202
41 to 45	142	81 to 85	211
46 to 50	151	86 to 90	219
51 to 55	159	91 to 95	228
56 to 60	168	96 to 100	237

Table 2:

Number of Open-Response Question Points	Estimated MTEL Score
2	20
3	20
4	28
5	36
6	44
7	52
8	60

Print the form below to calculate your estimated practice test score.

**Multiple-Choice Section**

Enter the total number of multiple-choice questions you answered correctly:

Use Table 1 above to convert that number to the score and write your score in **Box A**: A:

**Open-Response Section**

Enter the number of points (1 to 4) for your first open-response question:

Enter the number of points (1 to 4) for your second open-response question: =====

Add those two numbers (Number of open-response question points):

Use Table 2 above to convert that number to the score and write your score in **Box B**: B:

**Total Practice Test Score (Estimated MTEL Score)**

Add the numbers in **Boxes A and B** for an estimate of your MTEL score: A + B =